

IPC4020/IPC4022

Fault Detector and RTU



IPC4020 and IPC4022 are fault detectors for over current and earth fault, both with integrated remote terminal unit functionality.

This user's manual describes the interfaces and management of the devices. This includes:

- Overview
- Connection using the service port
- Configuration, reset and upgrade
- System interface
- Detector functions
- Event list, Site manager and transient fault recorder
- Commissioning and testing

Table of Contents

1	Safety Information	4
2	Abbreviations	5
3	Firmware	5
4	Overview	6
4.1	Front Panel – HMI	7
4.1.1	LED Indicators	7
4.1.2	Push-button for Local Acknowledge	8
4.2	Startup	8
4.3	Internal Supervision	9
4.4	Interfaces	9
4.4.1	RS485/RS422 port for IEC 60870-5-101 Slave and PDCIO	9
4.4.2	RS485-port for PDCIO and IEC 60870-5-101 Master - OPTIONAL	10
4.4.3	Ethernet Interface for IEC 60870-5-104 and Service Port	10
4.4.4	USB Port	10
4.4.5	Secondary Current Inputs, 1 A	11
4.4.6	Power Supply	11
5	Service Interface	12
5.1	Connecting using Ethernet	12
5.2	Connecting using USB	13
5.3	Login	14
5.4	Start Tab and Device Information	14
6	Configuration and Settings	15
6.1	Device Settings – Unit	19
6.2	Current sensors for over head lines – LOFA	19
6.3	Time synchronisation – NTP	21
7	Remote Control Interface	22
7.1	Events, Queues and Interrogation	23
7.2	General Settings – Communication	24
7.2.1	Communication – Ethernet	24
7.2.2	Communication – IEC 60870-5-101/104	25
7.2.3	IEC 60870-5-101 master - OPTIONAL	29
7.3	Binary inputs – I/O-addressing – Binary Inputs	31
7.3.1	Binary Inputs – Input 1-16/22/24	32
7.3.2	Binary Inputs – Detector <i>m</i>	33
7.3.3	Binary Inputs – IEC 60870-5-101 Master	35
7.3.4	Binary Inputs – PDCIO and PBI	35
7.4	Binary outputs – I/O-addressing – Binary Outputs	36
7.4.1	Binary Outputs – Output 1-8/12	37

7.4.2	Binary Outputs – Detector <i>m</i>	38
7.4.3	Binary Outputs – PDCIO and PBO	38
7.5	Analog Inputs (I/O-addressing – Analog Inputs)	40
7.5.1	Analog Inputs – Internal	41
7.5.2	Analog Inputs – Detector <i>m</i>	42
7.5.3	Analog Inputs – PDCIO and PAI	44
8	Detector Functions	45
8.1	General	45
8.2	Detection states	45
8.2.1	Evaluation of Earth Faults	46
8.2.2	Evaluation of Transient and Arcing Faults	47
8.3	Settings - Common	48
8.4	Settings - I/O Settings	49
8.5	Detector Settings – Detector <i>n</i>	50
8.5.1	Overcurrent	50
8.5.2	Earth Fault, General	51
8.5.3	Earth Fault Protrol	51
8.5.4	Non-Directional Earth Fault	53
8.6	Phase Break	54
8.6.1	Auto reclosing – OPTIONAL	54
9	Event log and Site Manager	56
9.1	Event log – Event log	56
9.2	Site Manager	57
10	Transient Fault Recorders – TFR	60
11	Upgrade of Firmware	64
11.1	IPC402x	64
11.2	PDCIO	64
12	Checklist for Commissioning and Testing	65
13	References	68

1 Safety Information



Only certified electricians are allowed to perform installation work.



National and local security guidelines must be followed.



Always short circuit the secondary conductors of the current transformers during maintenance or testing.



If the secondary circuit of the CT's are opened or if their earthing point is missing or removed while the primary side is energized, high voltages can be generated. In worst case these voltages can be deadly and damage isolation material. Energization of the CT's primary side is not permitted if the secondary side is open or not earthed.



Dangerous voltages can be present on the terminals, also when power is removed from the device.



Violation against the security guidelines can lead to fatalities, personal injury or considerable damage to equipment.



Avoid removing the cover of the IPC402x devices. If it is removed, ensure that all electronic components are protected against electrostatic discharge, ESD, by proper earthing of both the device and the personnel performing maintenance.



The device should be connected by a short ground lead to protective earth at terminal X4.2.

2 Abbreviations

IPC401x	Previous generation fault detectors – IPC4010, -11 and -12
IPC402x	IPC4020, IPC4020exp3, IPC4020exp6 or IPC4022
ASDU	Application Service Data Unit
COMTRADE	Common Transient Data Exchange
DHCP	Dynamic Host Configuration Protocol
EF	Earth Fault
ESD	Electrostatic Discharge
OC	Overcurrent
RTU	Remote Terminal Unit
NTP	Network Time Protocol
TFR	Transient Fault Record(-er)

3 Firmware

Some of the functions described in this document were introduced in firmware version 1-3.1.0.

4 Overview

IPC402x contains two or three printed circuit boards; base board, front board and, if applicable, an expansion board. Overview pictures of IPC4020/IPC4020exp3 and IPC4022 are shown in Figure 1 and Figure 2. More detailed descriptions of the devices can be found in the datasheets for the devices [1][2].

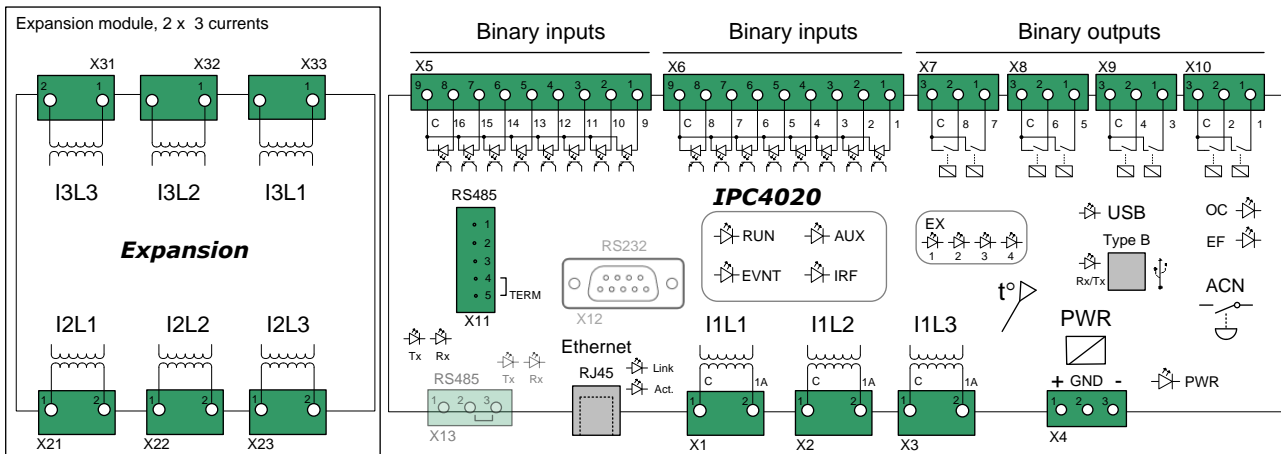

Figure 1. Overview IPC4020 with expansion for two extra detector functions (to the left). The outputs of contacts X8 and X10 are routed to more powerful relays.

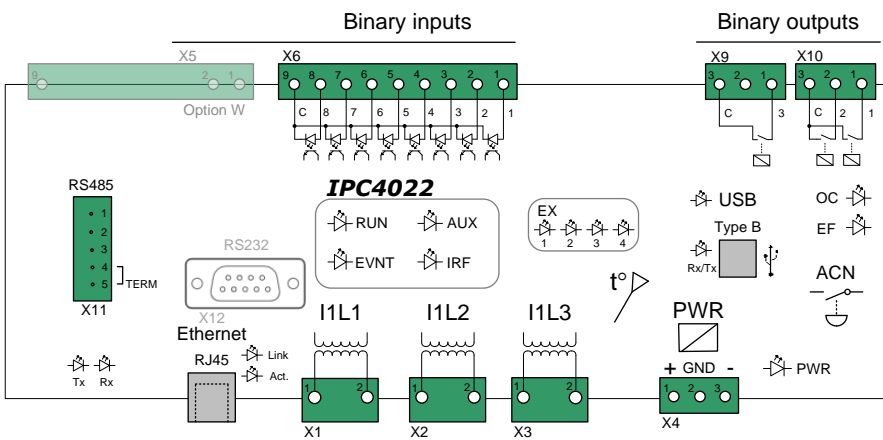

Figure 2. Overview IPC4022. The outputs on contact X10 are routed to more powerful relays.

The only normal reason to remove the front cover of the devices is to check the identification stickers that are located on the printed circuit boards, if requested. Each circuit board has a unique identity with the following format, see example beneath.

Manufacturing year and week: 1906

Batch identity: 46539

Sequence number: P0098

The sticker of the front board is located on the rear side of the board. It is not necessary to remove the front board to be able to see the identity number when needed during support cases or reclaims.

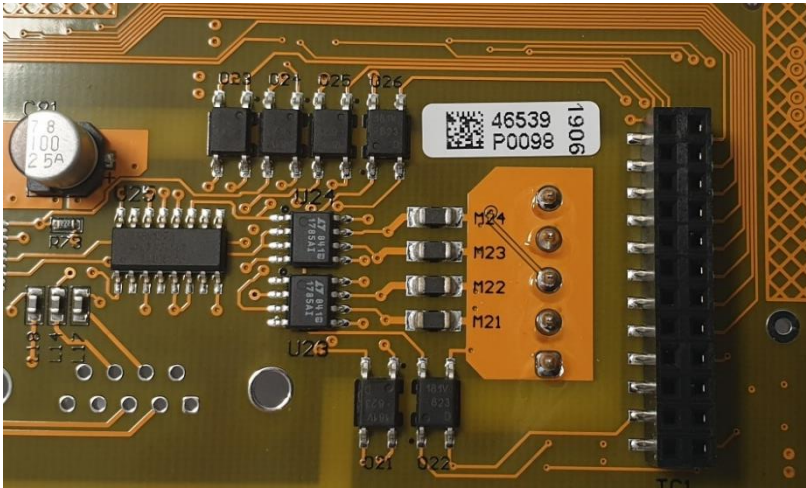

Figure 3. Example board identity.

4.1 Front Panel – HMI

4.1.1 LED Indicators

There are various LED indicators on the front panel for inputs, outputs, communication ports and status purposes.

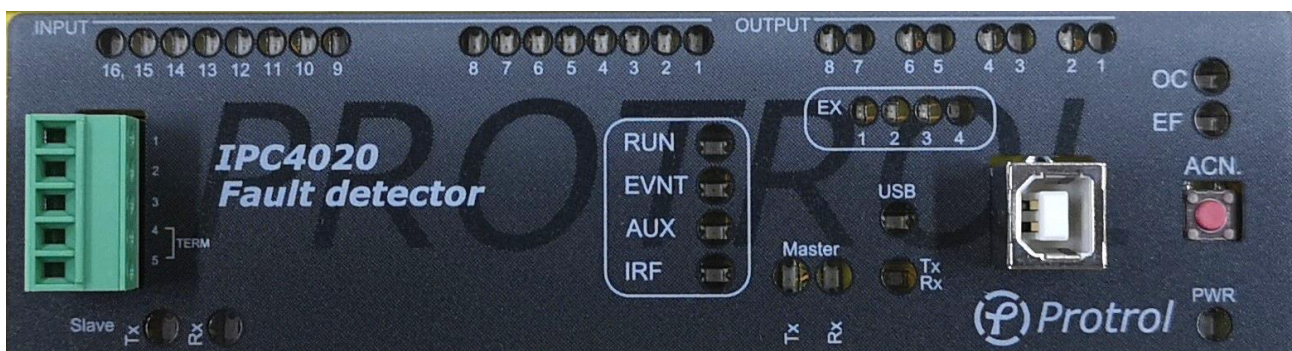

Figure 4. Front panel of IPC4020.

Each binary input and output have a LED above its screw terminal and reflects the position of the input/output. Voltage on an input activates the LED. Closed relay output activates the LED.

The table beneath describes the other LED indicators on the front panel.

LED	Description
PWR	Green diode indicating that the device is powered up
RUN	Green diode normally flashing at 0.5 Hz frequency
EVNT	Yellow diode indicating that there is an unsent telegram in the queue for slave transmission on the system interface
AUX	Yellow diode that normally indicates that the device is handling a frequency deviation
IRF	Red diode that indicates internal fault
USB	Yellow diode indicating a connected USB port
OC	Red diode indicating that an overcurrent has been detected
EF	Red diode indicating that an earth fault has been detected
Tx Master	Yellow diode indicating that a telegram is being sent on the serial master interface
Rx Master	Yellow diode indicating that a telegram is being received on the serial master interface
Tx Slave	Yellow diode indicating that a telegram is being sent on the serial slave interface
Rx Slave	Yellow diode indicating that a telegram is being received on the serial slave interface
Tx/Rx (USB)	Dual-coloured green-red diode which alternates when there is traffic on the USB port. USB LED is active when USB link is established.
EX1	Yellow diode indicating that Detector 1 has identified a fault
EX2	Yellow diode indicating that Detector 2 has identified a fault – applies to expanded device
EX3	Yellow diode indicating that Detector 3 has identified a fault – applies to expanded device
EX4	Yellow diode that in normal configuration indicates start fault detection, detector 1-3

Some LEDs, such as AUX and EX1-4, can have other functionality for certain option choices.

4.1.2 Push-button for Local Acknowledge

There is a push-button, ACN, on the far right of the front panel for local acknowledge of the overcurrent and earth fault indications including maximum fault current and faulty phase, and factory reset. Remote acknowledge from the dispatch center and automatic self-acknowledge after a configurable time delay are described in a separate chapter of this text manual.

4.2 Startup

After a restart of the device, i.e., if there has been a disturbance in DC supply or a restart has been ordered from remote, inputs and outputs are updated with the current status. Any outputs that were activated before the restart, return to inactive position unless the conditions for activation are valid.

4.3 Internal Supervision

Internal check of CPU-near hardware and software modules is performed at startup.

- Memory check – activates IRF
- Flash memory check – activates IRF
- Expansion board check – activates IRF
- Execution of software modules – activates IRF
- Supervision of external interfaces – reported in Event Log

Supervision of expansion boards and execution of software modules are performed continuously.

4.4 Interfaces

4.4.1 RS485/RS422 port for IEC 60870-5-101 Slave and PDCIO

IPC402x has a signal interface on the left of the front panel for connection to the remote control center using the communication protocol IEC 60870-5-101.

This port supports 2-wire (half duplex) communication. It is factory set to 8-E-1, i.e., 8 data bits, even parity and 1 stop bit. With options where the front panel is modified, it is possible to handle both 4-wire (full duplex) or RS232 communication.

There is built-in protection for surge voltages. However, cables for communication that may be subjected to overvoltage must have a primary protection, for example Protrol OVP. As a rule of thumb, one can say that cables that leave the building / station must be supplemented with a primary protection.

Terminals

Terminal/pin	Short name	Description
X11:1	TX+	Sender (plus)
X11:2	TX-	Sender (minus)
X11:3	RX(TX)+	Receiver (plus), (also sender when 2-wire)
X11:4	RX(TX)-	Receiver (minus), (also sender when 2-wire)
X11:5	TERM	Termination for receiver. Connect to X11:4 for activation

Terminering

The first (master) and last device (last slave device) on the communication line should be terminated. This is done on IPC402x by short-circuiting X11:4 and X11:5.

The terminals X11:3 and X11:4 are used for 2-wire communication. Configuration according to Chapter 7.2.

The terminal X11 can also be used as the physical interface when the expansion device PDCIO is used. PDCIO is connected to the terminals X11:3 and X11:4 in the same manner as when 2-wire-communication is employed for communication with the remote control centre using IEC 60870-5-101.

4.4.2 RS485-port for PDCIO and IEC 60870-5-101 Master - OPTIONAL

IPC4020 has another terminal X13 on the left lower side, where additional slave units that communicate with IEC 60870-5-101 can be connected. The port supports 2-wire communication (half duplex). It is factory set to 8-E-1, i.e., 8 data bits, even parity and 1 stop bit. This function and port are not available on IPC4022.

Note that the IEC 60870-5-101 Master function is an option and is ordered separately, see datasheet [1].

There is built-in protection for surge voltages. However, cables for communication that may be subjected to overvoltage must have a primary protection, for example Protrol OVP. As a rule of thumb, one can say that cables that leave the building / station must be supplemented with a primary protection.

The terminal X13 can also be used as the physical interface when the expansion device PDCIO is used. PDCIO is connected to the terminals X13:1 and X13:2.

Terminals

Terminal/pin	Short name	Description
X13:1	RX/TX+	Sender/Receiver (plus)
X13:2	RX/TX-	Sender/Receiver (minus)
X13:3	TERM	Line termination. Connect to X13:2 for activation.

Terminering

The first (master) and last device (last slave device) on the communication line should be terminated. This is done on IPC402x by short-circuiting X13:2 and X13:3.

4.4.3 Ethernet Interface for IEC 60870-5-104 and Service Port

There is an Ethernet interface, RJ45 10/100Base - TX Full Duplex, for communication via IEC 60870-5-104 and the remote control centre.

This interface is also used as a service port, i.e., for connecting a service computer using TCP/IP and accessing the built-in web interface of IPC402x.

4.4.4 USB Port

IPC402x is equipped with a service port for USB Type B. The port is located on the right of the front panel next to the local acknowledge push-button, ACN.

4.4.5 Secondary Current Inputs, 1 A

Current terminals for phase current transformers are found in the following locations:

- Detector 1: Terminals X1-X3 between the RJ45 connector for Ethernet and the terminal for power supply.
- Detector 2: Terminals X21-X23, lower side of the expansion module (left side of the RJ45 contact).
- Detector 3: Terminals X31-X33, see Overview for each product version in the datasheets.
- Detector 4: Terminals X34-X43, see Overview for each product version in the datasheets.
- Detector 5: Terminals X51-X53, see Overview for each product version in the datasheets.
- Detector 6: Terminals X61-X63, see Overview for each product version in the datasheets.

4.4.6 Power Supply

IPC402x requires an external power supply of 24-48 VDC which is connected to terminal block X4. The connection is not polarity sensitive.

The device must be connected to protective ground using terminal X4.2 and a short ground lead.

5 Service Interface

The built-in web server in IPC402x gives authorized access to all settings, status information, file transfer and event lists, either via Ethernet RJ45 or USB type B. Protrol recommends using Chrome or Firefox web browsers.

5.1 Connecting using Ethernet

The prerequisite for connecting via Ethernet is that the service computer has IP settings that match, i.e., the same subnet and subnet mask, with those of the IPC device that you want to connect to.

An IPC402x is supplied either with factory settings or with order-specific settings. The factory settings are as follows:

Parameter	Value
IP address	192.168.0.31
Net mask	255.255.255.0
Standard gateway	192.168.0.1

The above settings mean that the IPC is accessible via computers with addresses within the 192.168.0.x range, or redirected addresses via the gateway/router.

5.2 Connecting using USB

It is also possible to connect using USB type B. to do so, a separate software, Protrol USB Bridge for Windows 7/10, is needed. This is available on Protrol's website, together with a link to download necessary drivers. Below is a brief description of how to connect using this software.

1. Start Protrol USB Bridge.
 - a. If an IPC402x is found by the program, the current COM port is displayed. See the left image in Figure 5.
2. Click on **Open serial port**.
 - a. If the connected, the other buttons will light up. See the right image in Figure 5.
3. Open the default browser by clicking **Open web browser**.
 - a. To start the web browser manually, please enter `127.0.0.1:20080/` in the address bar.

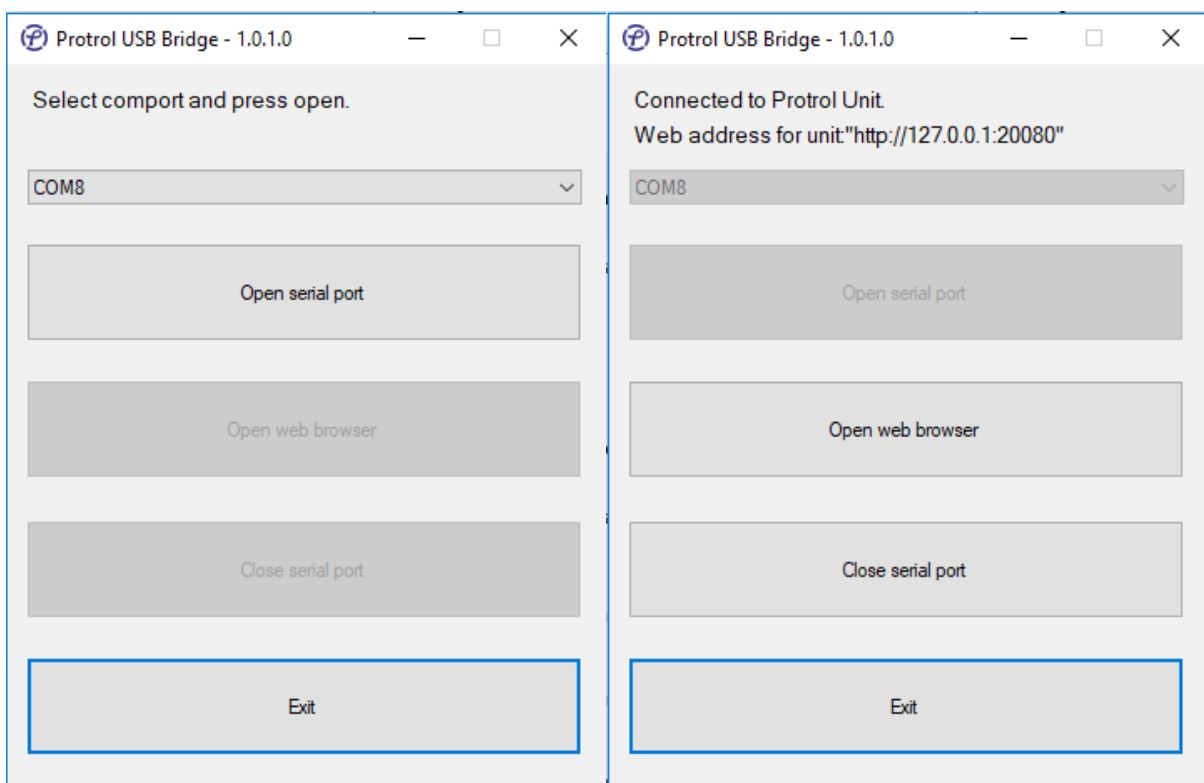

Figure 5. When starting Protrol USB Bridge, the left picture is displayed. Select the proposed COM port and click **Open serial port**. After this, it is possible to open the default browser by pressing **Open web browser** (right image).

5.3 Login

After connecting to the IPC402x device, a login screen is displayed. This includes information about the connected Protrol device and the input field for logging in.

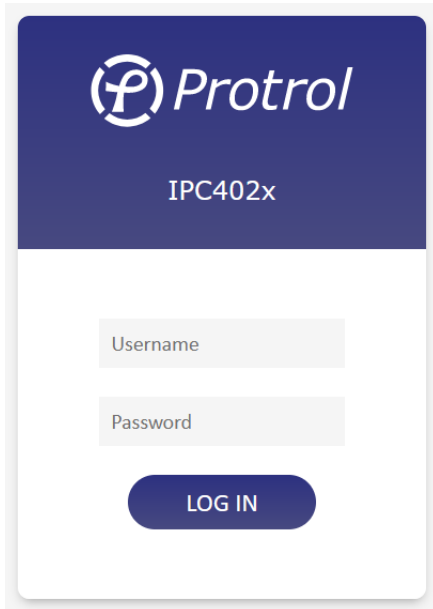

Figure 6. The login dialog of the integrated web server requires a login name and corresponding password.

The following standard users can be selected:

User	Default Password	User properties
status	status	Displaying settings Download of disturbance files
config	config	Display / change of normal settings Download of disturbance files Firmware upgrade
admin	availability	Same as <i>config</i> , and in addition user administration and password Display / change of special settings

Please observe that special characters cannot be used for passwords. Change of passwords is described in the following text.

5.4 Start Tab and Device Information

After logging in, the Start tab is displayed. This includes status and information about the connected device, as well as tabs for other functions.

At the bottom of all web pages, the unit's unique ID number and software versions can be found. Please copy the information field and attach it to any support case.

The service interface has a built-in timeout, which means that automatic logout is done after a period of inactivity.

6 Configuration and Settings

Configuration is done using the web interface. See chapter 4 for details on connection to the device and its web interface. The majority of the PDCIO parameters are configured in IPC4020.

All settings can be found on the **Config** tab:



Start	Config	Status	System				
Config operations:							
Unit	Read from unit	Write to unit					
File	Open...	Save as...					
<table border="1"> <thead> <tr> <th>Unit</th> <th>Communication</th> <th>I/O addressing</th> <th>Detector</th> </tr> </thead> </table>				Unit	Communication	I/O addressing	Detector
Unit	Communication	I/O addressing	Detector				

Write/Save settings:

- When new settings are to be saved and activated in the IPC unit, press the **Write to unit** button.
- The settings are then transferred to the device and it then restarts automatically. If PDCIO is connected, its parameters will be transferred at startup of the IP device and PDCIO will subsequently be restarted. Note! It is important that the PDCIO device is connected and functions normally when pressing the **Write to unit** button, otherwise new settings will not be transferred to the device.
- You need to login again after the restart.
- The settings can also be saved to a local file using the **Save as...** button.

Read/Open settings:

- If settings are to be read from the device, press the **Read from unit** button.
- Settings saved on file are loaded using the **Open...** button.

Reset settings:

- IPC402x is delivered either with Protrol's *factory defaults* or with specific customer settings (*delivery defaults*) according to agreement between Ensto Protrol and the customer.
- Reset to *factory / customer settings* is made on the **System** tab.

Restore factory/delivery settings (preserve IP)

Overwrite the current user settings with the most recent factory and/or delivery settings but preserves the current Ethernet IP settings.

Reset settings

Note that passwords for the different login levels are also reset.

Internet settings, the device's IP address, etc., are not reset.

This also applies to IP addresses for IEC 60870-5-104.

- Complete reset to *factory / customer settings*:

A complete reset, including all Internet settings, can be done in two different ways:

1. From web interface.

Note that there is a great risk of losing the ability to remotely connect to the device after the reset, depending on the changed IP address and other internet settings!

In order to be able to make a complete reset via the web interface, the user must log in as the administrator **admin**.

On the **System** tab you first activate specialist mode, by pressing the button **Display specialist settings**. After that the button for full reset is displayed, **Reset settings to delivery / factory defaults**.

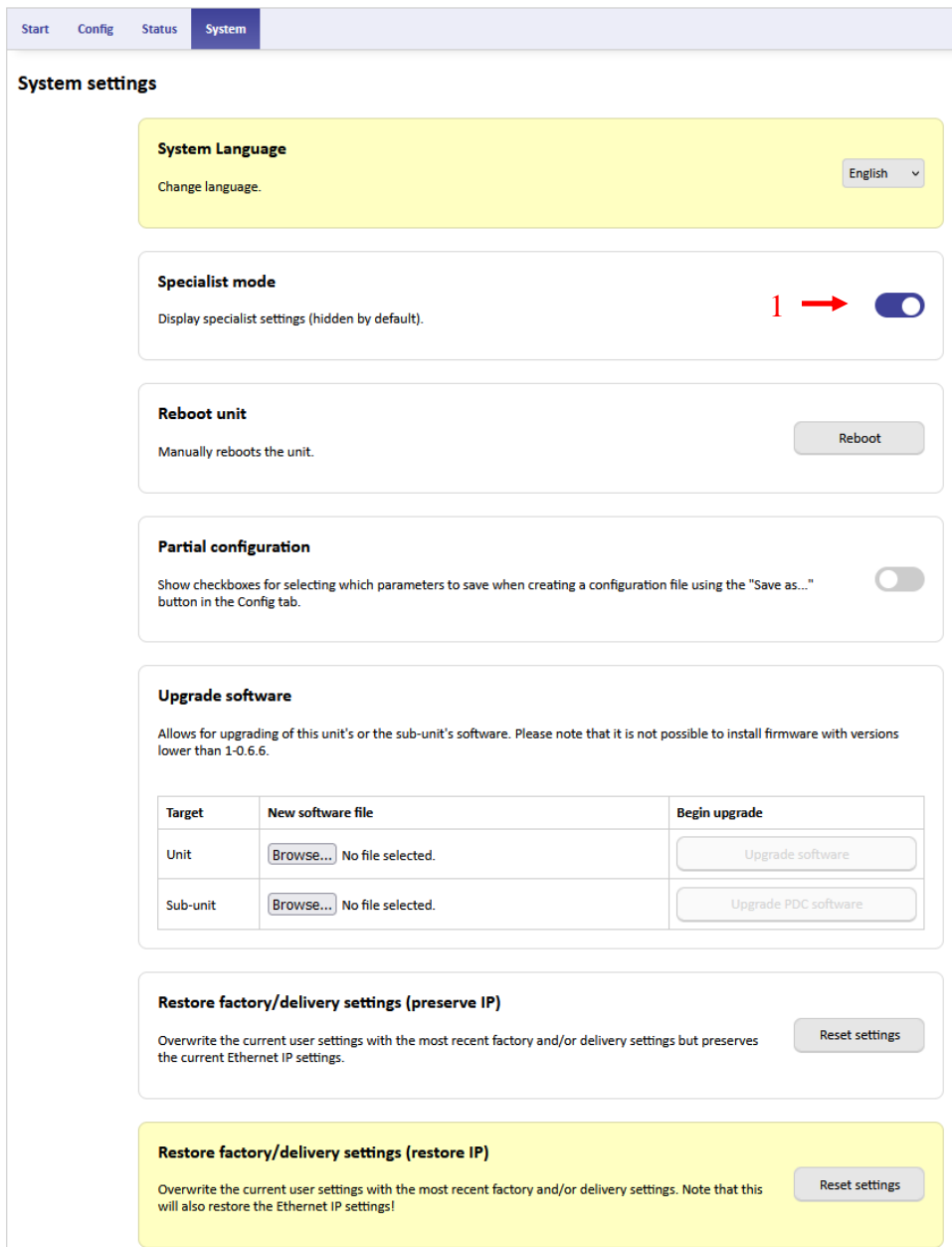

Start Config Status **System**

System settings

System Language
Change language. English ▾

Specialist mode
Display specialist settings (hidden by default). 1 →

Reboot unit
Manually reboots the unit. Reboot

Partial configuration
Show checkboxes for selecting which parameters to save when creating a configuration file using the "Save as..." button in the Config tab.

Upgrade software
Allows for upgrading of this unit's or the sub-unit's software. Please note that it is not possible to install firmware with versions lower than 1-0.6.6.

Target	New software file	Begin upgrade
Unit	<input type="button" value="Browse..."/> No file selected.	<input type="button" value="Upgrade software"/>
Sub-unit	<input type="button" value="Browse..."/> No file selected.	<input type="button" value="Upgrade PDC software"/>

Restore factory/delivery settings (preserve IP)
Overwrite the current user settings with the most recent factory and/or delivery settings but preserves the current Ethernet IP settings. Reset settings

Restore factory/delivery settings (restore IP)
Overwrite the current user settings with the most recent factory and/or delivery settings. Note that this will also restore the Ethernet IP settings! Reset settings

2. Using the ACN button.

A full reset to factory/customer settings can also be done using the *acknowledge* button (ACN) on the front card by following these steps:

- Restart the device by power cycling it.
- Press and hold the ACN button when the first LEDs light up (IRF etc.).
- After a while the EX LEDs are lit. Release the ACN button before they have counted down entirely.
 - Avoid a reset by pressing the ACN button until the device is in normal operation.
- The unit now resets the settings and then restarts.

User administration:

Activation/deactivation of users and replacement of passwords are made on the **Config/Accounts** tab.

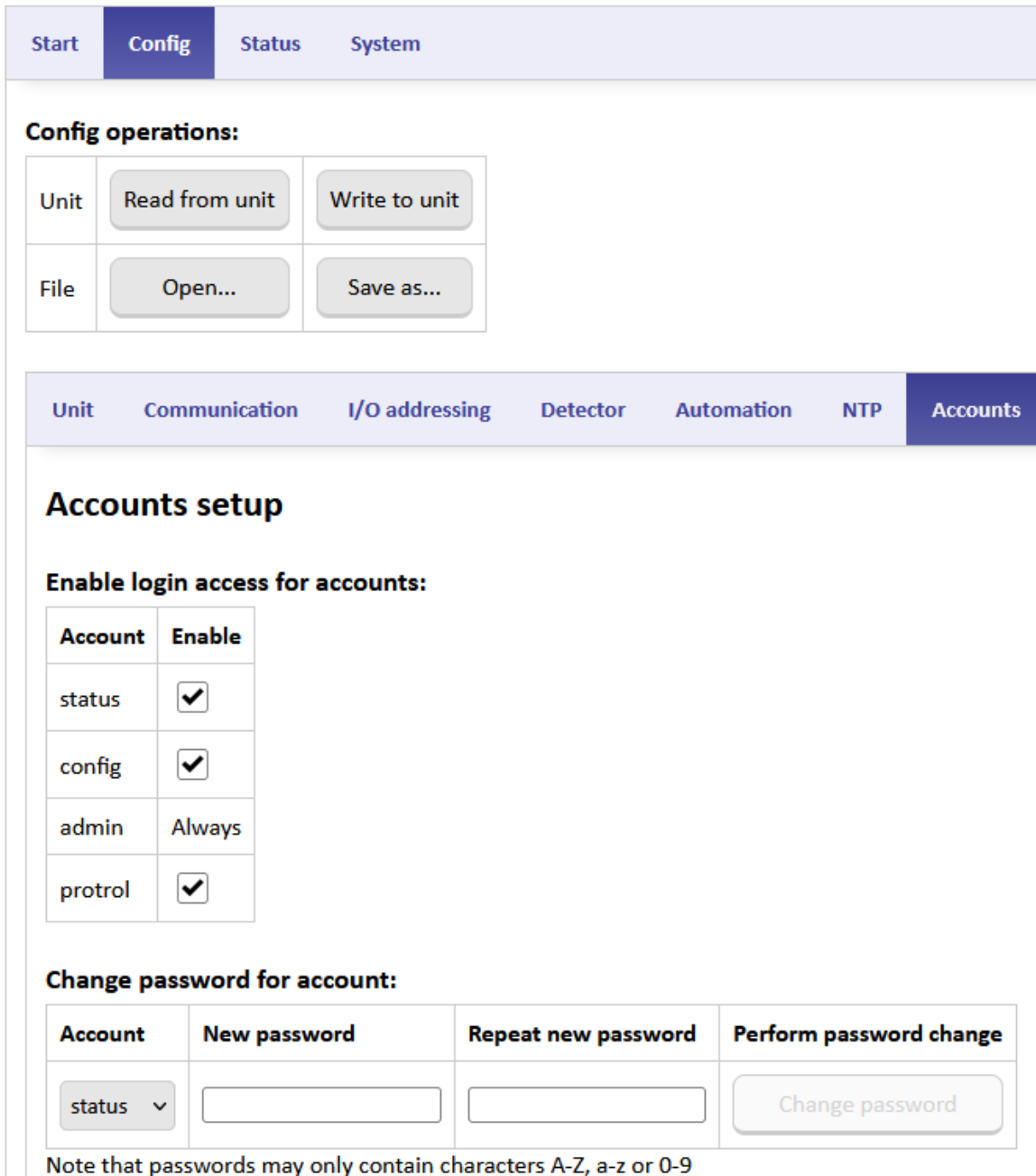

Config operations:

Unit	Read from unit	Write to unit
File	Open...	Save as...

Unit Communication I/O addressing Detector Automation NTP **Accounts**

Accounts setup

Enable login access for accounts:

Account	Enable
status	<input checked="" type="checkbox"/>
config	<input checked="" type="checkbox"/>
admin	Always
protrol	<input checked="" type="checkbox"/>

Change password for account:

Account	New password	Repeat new password	Perform password change
status ▾	<input type="text"/>	<input type="text"/>	Change password

Note that passwords may only contain characters A-Z, a-z or 0-9

Figure 7. Administration of accounts can be done when the user is logged in as **admin**.

The administrator can activate/deactivate all accounts except for the Admin account. Please observe that the passwords can only consist of capital letters, lower case letters and the numbers 0-9. Special characters and other national characters are not allowed.

6.1 Device Settings – Unit

The IPC device has general settings on the **Unit** subtab, listed in the table beneath. The *Watchdog* relay closes when all is normal. If there is an internal fault, the relay opens. If power supply is missing, the relay will remain open.

Parameter	Description	Range	Factory value	Unit
Unit information:				
Site	Site reference ¹	-	Sitename...	-
Free Text	Text of choice for extra information	-	-	-
Watchdog output:				
Enable	Activation of the Watchdog feature	Yes or No	No	-
Watchdog relay	Choice of relay output	1..8	1	-
PDCIO external I/O:²				
Enable	Activation of external I/O-module PDCIO	Yes or No	No	-
DAT3012³:				
Enable	Activation of external PT100 modul DAT3012	Yes or No	No	-

Specialist settings

Parameter	Description	Range	Factory value	Unit
LOFA:				
Enable	Enabling the external current sensor LOFA	Yes or No	No	-

6.2 Current sensors for over head lines – LOFA

IPC402x is available with current sensors, LOFA, for up to three overhead lines. Upon delivery, the IPC device is configured with calibration data for the current sensors to be used. There can be reasons to update calibration data, for example, if the IPC402x or the any of the current sensors need to be replaced. Management of calibration information is done on the tabs **Config/LOFA/LOFA x**.

Read/Open settings:

- Reading of settings is automatically performed when the web server is accessed. The settings can be reloaded by pressing **Read from unit**.
- Settings stored on file can be uploaded to the web browser by pressing **Load saved LOFA calibration**. After this, they are displayed in the web browser but have not yet been downloaded to the IPC402x device.

¹ If the disturbance recording files shall be visualized using Protrol-Tool, the station name is not allowed to have spaces. Alternatively, the files must be edited before they can be loaded by the tool.

² PDCIO is described in detail in its own user's manual [4]. Connects to terminal X11 on the front panel or X13.

³ Connects to terminal X13. DAT3012 cannot be used in conjunction with the function IEC 60870-5-101 master.

Write/Save settings:

- To save and activate new settings, press **Write to unit**.
- The settings are first transferred to from the web browser to the IPC device. When this is successful, the device will restart automatically with the new settings activated.
- The settings can be backed up to file. This is done by pressing **Save current LOFA calibration**.

The Status LED shows status information for the LOFA sensors as follows:

- Green – IPC402x is configured for using LOFA
- Yellow – Calibration mode is activated

Unit	Communication	I/O addressing	Detector	Automation	NTP	LOFA	Accounts
------	---------------	----------------	----------	------------	-----	------	----------

LOFA settings

Calibration operations:

Mode	Activate LOFA calibration mode	Deactivate LOFA calibration mode
Operation	Update LOFA calibration values	

Config operations:

Unit	Read from unit	Write to unit
File	Load saved LOFA calibration	Save current LOFA calibration

Information:

Status		LOFA running normal operation
--------	---	-------------------------------

Note that phase values below are only valid when LOFA calibration is active.

Phase	CT name	Current	Phase	CurrCalib	PhaseCalib
L1	ct1	0.0	0	1.000	0.000
L2	ct2	0.0	0.0	1.000	0.000
L2	ct3	0.0	0.0	1.000	0.000

Figure 8. The LOFA tabs are used when calibration data need to be updated or saved to file.

6.3 Time synchronisation – NTP

IPC402x has support for time synchronization using NTP. Settings can be found on the **Config/NTP** tab.

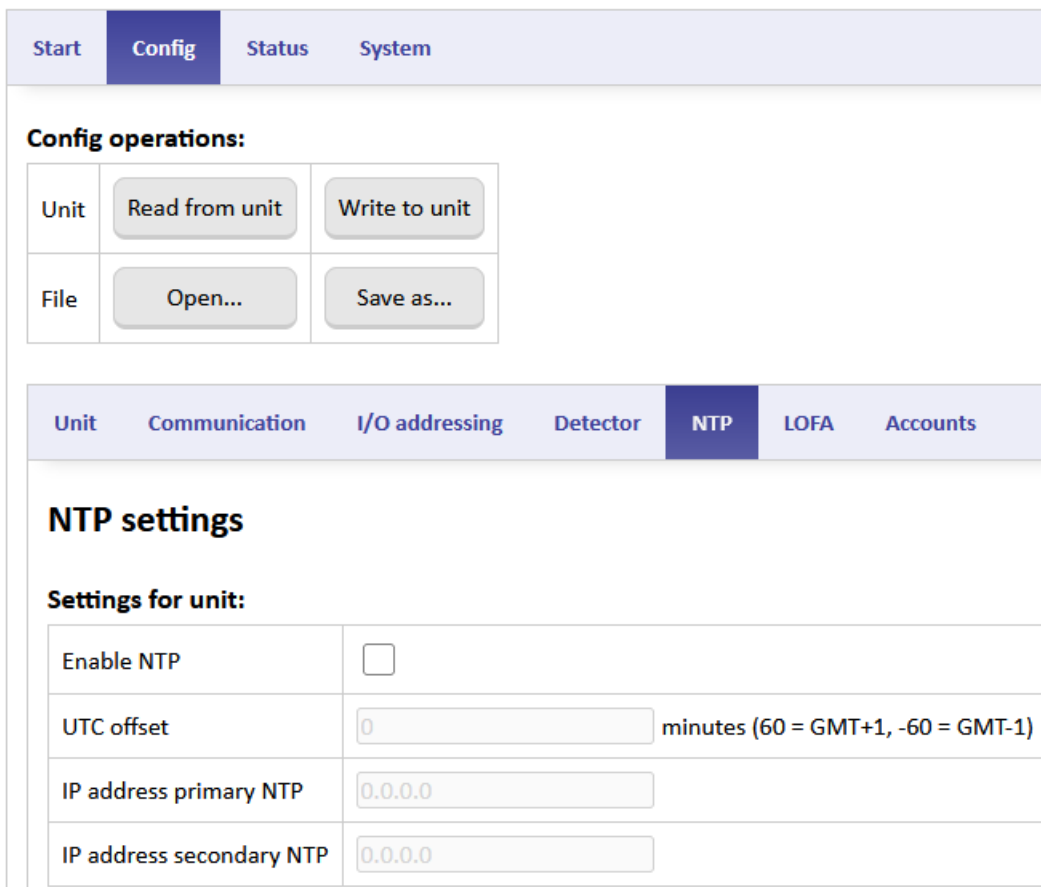

The screenshot shows the Protrol configuration interface. At the top, there are tabs for 'Start', 'Config', 'Status', and 'System'. The 'Config' tab is active. Below this, there are 'Config operations' buttons: 'Read from unit', 'Write to unit', 'Open...', and 'Save as...'. A secondary set of tabs includes 'Unit', 'Communication', 'I/O addressing', 'Detector', 'NTP', 'LOFA', and 'Accounts'. The 'NTP' tab is selected, displaying 'NTP settings'. Under 'Settings for unit:', there are four rows: 'Enable NTP' with an unchecked checkbox; 'UTC offset' with a text input field containing '0' and the label 'minutes (60 = GMT+1, -60 = GMT-1)'; 'IP address primary NTP' with a text input field containing '0.0.0.0'; and 'IP address secondary NTP' with a text input field containing '0.0.0.0'.

Figure 9. Configuration of NTP.

Parameter	Description	Range	Factory value	Unit
Enable NTP	Activation of NTP	Yes or No	No	-
UTC offset	Adjustment, offset, of time	-900..900	0	min
IP address primary NTP	Primary NTP server	-	0.0.0.0	-
IP address secondary NTP	Secondary NTP server	-	0.0.0.0	-

IPC402x time is used for time stamping of indications, events, and disturbance recordings. The time resolution is 1 ms.

When NTP is activated, time synchronisation using IEC 60870-101/-104 is disabled.

7 Remote Control Interface

IPC402x includes an integrated RTU (Remote Terminal Unit) function.

All physical binary and analog inputs can be configured to communicate values to a remote control system. Physical outputs can be set up to be controlled from remote.

Also events from detector functions as well as various objects for activation (e.g. *Autoreclosure*) and objects for acknowledgment can be assigned to the remote control system.

IPC402x supports the communication protocols IEC 60870-5-101 and IEC 60870-5-104.

In addition, there is an option which makes it possible to use IPC4020 as a local -101 Master. With this option it is possible to connect several -101 slaves to IPC4020 and access them in the remote control center. This option is not available for IPC4022.

Please observe that IEC 60870-5-101 Master is optional and must be ordered separately, refer to the datasheet [1].

IEC 60870-5-101:

- Physical interface for IEC 60870-5-101 is RS485 (X11) or RS232 (X12 DSUB9, optional).
- Both 2 and 4 wire communication is supported for RS485 communication.
- Terminate RS485 by short-circuiting inputs 4 and 5 on the X11 terminal. Only the last device should be terminated if there additional IPC402x on the same RS485 loop.

IEC 60870-5-104:

- Physical interface for IEC 60870-5-104 is RJ45 10/100Base – TX Full Duplex.

IEC 60870-5-101 Master - OPTIONAL:

- Physical interface for IEC 60870-5-101 Master is 2 wire communication via RS485 (X13).
- Refer to kapitel 4.4.2 for detailed information regarding the physical connection.
- Please observe that IEC 60870-5-101 Master is optional, refer to the datasheet [1].

For more information regarding settings for communication, objects and more, see the following chapters.

A general description on how to configure IPC402x can be found in Chapter 6.

7.1 Events, Queues and Interrogation

Status changes of physical binary inputs and internal logical events are timestamped upon detection with a time resolution of 1 ms. If the status change is shorter than 1 ms, the event is suppressed. Events are added to internal queues and sent in the order of creation. The EVT LED on the device is active when events are waiting to be transported on the system interface.

For analog signals, changes larger than the deadbands result a message which is added to the internal queues. See Section 7.5 Analog Inputs (I/O-addressing – Analog Inputs) for detailed information about configuration. Normally, only the last analog message per signal is kept in the buffers. It is possible to activate buffering of analog signals if that is desired.

The queues are using the principle FIFO – *First In First Out* and can buffer a maximum of 500 events. When a queue is full, the oldest event is discarded to make place for the last event. If the event queues are not full, all status changes will generate time stamped event messages and no information is lost.

There are functions that will limit the creation of events when an input changes status too often. See chapter 7.3.1 Binary Inputs – Input 1-16/22/37 for more information.

When a communication link has been initiated by the master interface, events are transmitted according to the chosen protocol and a prioritized order (class 1 and 2 for IEC 60870-5-101/104). For IEC 60870-5-104, the events are sent immediately when they have been added to the queues. If IEC 60870-5-101 is used, the events are transmitted after requests from the master interface.

At general interrogation, events are created for all objects defined in the device. The current status of all input signals, physical and logical, are collected and added to internal queues with no delay. The events are sent in the order they have been added to the queues.

If the IPC device is acting master for other slaves, it will collect events from all active slaves. Due to speed limitations in the master-slave transmission there will be a delay until all status updates are retransmitted to the control center.

7.2 General Settings – Communication

This section describes the configuration settings for remote communication; IP addresses, and general settings for IEC 60870-5-101 and IEC 60870-5-104.

7.2.1 Communication – Ethernet

The settings for *Ethernet* are found on the *Config/Communication/Ethernet* tab:

Unit	Communication	I/O addressing
Ethernet	IEC 60870-5-101/104	

Settings - Ethernet:

Parameter	Description	Range	Factory value	Unit
Settings for unit:				
Enable static IP	Fixed or dynamic IP address (via DHCP).	Yes or No	Yes	-
IP address	Fixed IP address for the device.	1	192.168.0.31	-
Netmask	Netmask	1	255.255.255.0	-
Gateway	IP address for network gateway	1	192.168.0.1	-
DNS primary	IP address for primary DNS	1	8.8.8.8	-
DNS secondary	IP address for secondary DNS	1	1.1.1.1	-
Trusted IP addresses for IEC 60870-5-104:				
IP address n	Address n of IEC 60870-5-104 master ($n = 1, 2, \dots$)	1	192.168.0.10 n	-
Enable n	Accept connection from this address. If no address is specified, connection is accepted from all addresses (within the Netmask).	Yes or No	No	-

¹ Range according to common notation (4 bytes in decimal form, 0..255). Observe that the address 0.0.0.0 is not allowed.

7.2.2 Communication – IEC 60870-5-101/104

There are three sub-tabs on the *IEC 60870-5-101/104* tab, or four if the option “-101 Master” is enabled.

Unit	Communication	I/O addressing
Ethernet	IEC 60870-5-101/104	
Common	-101 slave	-104 slave

Each tab and its settings are described in the following sections.

7.2.2.1 IEC 60870-5-101/104 – Common

Settings – Common:

Parameter	Description	Range	Factory value	Unit
Common address (CA)	Common ASDU address. Can have range 1 octet or 2 octets.	1..254 1..65 534	1	-
Use end of init (M_EI)	The device shall send a startup message.	Yes or No	Yes	-
Slave interface	Choice of remote control interface	No slave, -101 slave, -104 slave	-104 slave	-
Select timeout	Specifies how long to wait for the Execute command after an object has been Selected. If no Execute command arrives within the set time, the order will be interrupted.	1..3 600	30	s
Cyclic analog transmission	Period for cyclic transmission of analog values Value 0 means that the function is disabled.	0..86 400	0	s
Invert double point open/close for all physical Binary inputs	Invert all physical open/close indications for binary inputs.	Yes or No	No	-
Invert double point open/close for all physical Binary outputs	Invert all physical open/close orders for binary outputs.	Yes or No	No	-

IEC -101 master¹

Option				
Master interface	Choice of interface to sub-slaves	No master, -101 master	No master	-

Specialist settings

Parameter	Description	Range	Factory value	Unit
Only send positive flank from detector	Transfer indications only at status change from OFF -> ON.	Yes or No	No	-
Queue analog events	Activate buffer for analog signals.	Yes or No	No	-
Only send packed data	For option LoRaWAN – if activated, only a pre-determined set of signals will be transmitted.	Yes or No	No	-
Chattering analog input blocking time	Minimum update interval for analog signals. Value 0 means that analog signals are updated when the deadband is exceeded. Otherer blocking times are limited by the parameter Cyclic analog transmission if it is set >0.	0..86 400	3000	ms
Output command short pulse	A command order can be specified for short pulse duration (qualifier of command). This requires that the object parameter Pulse time is set to zero for the object of interest.	0..65 535	100	ms
Output command long pulse	A command order can be specified for long pulse duration (qualifier of command). This requires that the object parameter Pulse time is set to zero for the object of interest.	0..65 535	1000	ms

¹ IEC -101 master is an option that needs to be specified upon order. This option is not available if the device is configured for IEC -101 slave and connected to PDCIO.

7.2.2.2 IEC 60870-5-101/104 – -101 slave

Settings - 101 slave:

Parameter	Description	Range	Factory value	Unit
Protocol settings:				
Link address (LA)	Link address (RTU address). Can have range 0, 1 octet or 2 octets.	1..254 1..65 534	1	-
Common address (CA)	RTU address. Configured on the <i>Common</i> tab.	- ¹	-	-
Time tag type	Specifies what type of time format IPC402x uses.	- ¹	CP56	-
Link address (LA) size	Size of link address.	0..2	1	octets
Common address (CA) size	Size of RTU address.	1..2	2	octets
Object address (OA) size	Size of Object address.	1..3	3	octets
Cause of transmission (COT) size	Size of "COT".	1..2	2	octets
Port settings:²				
Port type	Choice of physical interface: 1. 2 wire RS-485 2. 4 wire RS-422 3. RS-232 (without hand shake) 4. RS-232 (with hand shake)	1..4	1	-
Baud rate	Communication speed.	1 200, 2 400, 4 800, 9 600	9 600	Bit/s
Response delay	Delay before response is transmitted.	2..1 000	10	ms

¹ This is for information only and cannot be changed by the user.

² The port is set to 8-E-1, i.e., 8 data bits, even parity and 1 stop bit.

7.2.2.3 IEC 60870-5-101/104 – -104 slave

Settings - 104 slave:

Parameter	Description	Range	Factory value	Unit
APDU timeout (t1)	Time limit for sent unconfirmed message. If the time has expired, communication is closed.	1..3600	15	s
ACKN timeout (t2)	Deadline for received unconfirmed messages. Confirmation (ackn) is sent no later than this time.	1..3600	10	s
TEST timeout (t3)	Test message timeout. Test message is sent no later than this time.	1..3600	30	s
k unackn I format ASDU	Maximum number of unconfirmed messages (I format). If exceeded, communication is closed.	1..255	12	-
w ackn I format ASDU	Maximum number of unconfirmed received messages (I format). Confirmation (ackn) will be sent no later than this number.	1..255	8	-
Command timetag timeout	Maximum difference between local time in the unit and time marking on an order. If the telegram does not arrive in time, the order is not allowed.	1..3600	30	s
Time tag type	Specifies the type of time format IPC402x uses.	- ¹	CP56	-
Common address (CA) size	Size of the RTU address, number of octets.	- ¹	2	octet
Object address (OA) size	Size of the object address, number of octets.	- ¹	3	octet
Cause of transmission (COT) size	Size of "COT", number of octets.	- ¹	2	octet

¹ This is for information only and cannot be changed by the user.

7.2.3 IEC 60870-5-101 master - OPTIONAL

IPC4020 can be obtained with the option *IEC -101-master for IPC402x*. With this option, IPC4020 can act local IEC-101 master, which enables the user to connect an additional number of local -101 slaves.

The settings are found on the *Communication/IEC 60870-5-101/104/-101 master* tab.

Unit	Communication	I/O addressing	Detector	NTP
Ethernet	IEC 60870-5-101/104			
Common	-101 slave	-104 slave	-101 master	

General guidelines:

- The address size settings (parameters on line 3-6 in the table on the following page) must be identical to those which are used by the SCADA system (-101 or -104 slave).
- The values of Common and Link Address must match for master and slave.
- If the checkbox *Use master common address* is checked, the following applies:
 - The master cannot have a value in the upper octet of the object addresses.
 - All objects of all slaves must have unique object addresses. The SCADA system interpretes it as all objects are from the same RTU, i.e., the IPC4020 that acts -101 master.
 - For the -101 master to be able to resend commands from the remote control center, each upper octet of every object address **must** be identical to the Common address of the slave. Please see the following examples.
 - Binary output 3, in the second slave, shall be controlled by the SCADA system.
 - In this example, the second slave has Common address 5.
 - Binary output 3 has typically object address **21003** in the factory settings. This must be changed to **5.21003** (structured address), which equals 348 683 decimal.
 - The common address for the slave must be between 1 and 254.
- If the checkbox *Use master common address* is NOT checked, there are no restrictions to the choice of object addresses. In that case, the remote control system experiences all slaves as separate RTU's.
- If contact with a slave is lost, all objects belonging to that slave are sent to the remote control center with the Invalid flag set. This, however, is only done if an interrogation previously has been made from this specific slave. In addition, an object indicating lost slave communication is activated (see section 7.3.3)

Settings - 101 master¹:

Parameter	Description	Range	Factory value	Unit
Protocol settings:				
Use master common address	See description on previous page.	Yes or No	Yes	-
Time tag type	Specifies the type of time format IPC402x uses.	- ²	CP56	-
Link address (LA) size	Size of link address.	0..2	1	octets
Common address (CA) size	Size of RTU address.	1..2	2	octets
Object address (OA) size	Size of Object address.	1..3	3	octets
Cause of transmission (COT) size	Size of "COT".	1..2	2	octets
Slave link addresses, Slave x:				
Link address x	Link address of local slave(s). Can have length 1 or two octets. 0 means no slave is connected.	0..254 0..65 534	0 ³	-
Common address x	RTU address for local slave(s). Can have length 1 or 3 octets. 0 means no slave is connected.	0..254 0..65 534	0	-
Port settings: ⁴				
Port type	2-wire RS-485	- ¹	-	-
Baud rate	Communication speed.	1 200, 2 400, 4 800, 9 600	9 600	Bit/s

¹ IEC -101 master is an option that must be specified upon order.

² This is for information only and cannot be changed by the user.

³ Address 0 means that no slave is expected to be connected.

⁴ The port is set to 8-E-1, i.e., 8 data bits, even parity and 1 stop bit.

7.3 Binary inputs – I/O-addressing – Binary Inputs

Communication settings for all binary inputs are found under *Config – I/O-addressing – Binary Inputs*.

Unit	Communication	I/O addressing	Detector	NTP
	Binary inputs	Binary outputs	Analog inputs	
	Input 1-16	Detector 1	-101 master	

On the tab *Input 1-16/22/24*¹ all physical and system signals such as ACN push button and IRF are listed.

The *Detector m* tab contains binary objects for the detector functions. Up to six detectors can be used, the settings are identical.

All binary inputs can be setup in the same manner. Beneath is a general description.

For more information on each specific object, please refer to the chapter that describes it.

Parameter	Description	Range	Unit
Description	Brief descriptive name for the object.	-	-
Type	Type of indication; Single or Double ² .	Single point, Double point	-
Settings – Blocked	The signal is blocked, i.e. no value / status is sent to the remote end. Also applies to "interrogation" (status request).	Yes or No	-
Settings – Negative	The signal is inverted, i.e. a high signal is transmitted with status low to remote end.	Yes or No	-
Settings – Time tagged	The signal is timestamped upon change. The time is also sent to the remote end.	Yes or No	-
Delay	Number of milliseconds after the signal has changed status before a message is sent to the remote end. Applies to a positive change state change (0 -> 1). When Settings – Negative has been chosen, the opposite applies.	0 ... 65 535	ms
Address 8	Upper octet of the address. Decimal representation.	0 ... 255	-
Address 16	Lower octets of the address. Decimal representation.	0 ... 65 535	-

¹ If the device is an IPC4020exp4 or IPC4020exp6, there are additional physical binary inputs available.

² If Double point is used, this means for indication <OFF> that input *n* is high and input *n+1* is low. Input *n* low and input *n+1* high results correspondingly in indication <ON>.

7.3.1 Binary Inputs – Input 1-16/22/24¹

Settings for binary objects connected to physical inputs on the device, ACN button and IRF.

Limitation of events from binary inputs that change status frequently can be made using the parameter **Delay**, see description in the table on the previous page.

Only specific settings and differences to the normal are described below. See chapter 7.3 for a general description of the various configuration options.

The objects have the following factory settings:

- **Type** - *Single point*
- **Settings – Blocked** - No
- **Settings – Negative** - No
- **Settings – Time tagged** - Yes
- **Delay** - 0 ms

Settings – Input 1-16/22/24:

Parameter	Description	Factory value address lower octets ²
Ack button	Object linked to the ACN button on the front panel. Can only have the type <i>single indication</i> .	100
Input <i>n</i>	Object linked to physical input <i>n</i> (<i>n</i> = 1-15).	100+ <i>n</i>
Input 16	Object linked to physical input 16. Can only have the type <i>single indication</i> .	116
IRF	Indication for internal error. Can only have the type <i>single indication</i> .	117
Input 16 + <i>n</i>	Object linked to physical input 16 + <i>n</i> (<i>n</i> = 1-5) of IPC4020exp4 and IPC4020exp5/6.	150+ <i>n</i>
Input 22	Object linked to physical input 22 of IPC4020exp4 och IPC4020exp5/6. Can only have the type <i>single indication</i> for IPC4020exp5/6.	156
Input 23	Object linked to physical input 23 of IPC4020exp4.	157
Input 24	Object linked to physical input 24 of IPC4020exp4.. Kan endast ha typen enkelindikering.	158

¹ If the device is an IPC4020exp4 or IPC4020exp6, there are additional physical binary inputs available.

² Övre oktetten är alltid 0 som fabriksvärde.

7.3.2 Binary Inputs – Detector *m*

Binary object settings associated with detector functions.

Only specific settings and differences to the normal are described below. See chapter 7.3 for a general description of the various configuration options.

None of the indications can be of *double* type.

The objects 1-10 have the following factory settings:

- **Type** - *Single point*
- **Settings – Blocked** - No
- **Settings – Negative** - No
- **Settings – Time tagged** - Yes
- **Delay** - 0 ms

None of the objects 1-10 can be of the type double indication.

The objects 11-13 have the following factory settings:

- **Type**
 - Logical input 1: *Double point*
 - Logical input 2: *Single point*
 - EF Trip (reignition): *Single point*
- **Settings – Blocked** - Yes
- **Settings – Negative** - No
- **Settings – Time tagged** - No
- **Delay** - 0 ms

For more information regarding detector functions and their specific signals, refer to chapter 8.

Settings – Detector *m*:

Parameter	Description	Factory value address lower octets ¹
OC Start	Overcurrent – START indication	<i>m</i> 20
OC1 Trip	Overcurrent – TRIP indication, level 1	<i>m</i> 21
OC2 Trip	Overcurrent – TRIP indication, level 2	<i>m</i> 22
EF Start	Earth fault – START indication	<i>m</i> 23
EF Trip	Earth fault – TRIP indication	<i>m</i> 24
EF Start (non dir.)	Earth fault, non-directional – START indication	<i>m</i> 25
EF Trip (non dir.)	Earth fault, non-directional – TRIP indication	<i>m</i> 26
Phase break	Indication for phase break	<i>m</i> 27
OC Trip Ind	Indication mirroring the LED OC Trip.	<i>m</i> 28
EF Trip Ind	Indication mirroring the LED EF Trip.	<i>m</i> 29
Logical input 1²	Logical object 1, from additional software functions.	0 (Not activated)
Logical input 2	Logical object 2, currently not used	0 (Not activated)
EF Trip (reignition)	Earth fault – TRIP indication at arcing earth fault	0 (Not activated)

¹ *m* = 1 – 6 depending on the detector. Factory settings for the upper octet are always 0.

² Option: RECL OFF/ON, Auto reclosure inactive / activated.

7.3.3 Binary Inputs – IEC 60870-5-101 Master

If the IPC4020 device is configured to be master, see section 0, an additional subtab is displayed which lists binary inputs that mirror the status of the slaves. Configuration of these supervision objects is made in the same way as for other logical inputs.

See section 7.3 Binary inputs for the general description of object settings.

The supervision objects have the following factory settings:

- **Type** - *Single point (fixed)*
- **Settings – Blocked** - Yes
- **Settings – Negative** - No
- **Settings – Time tagged** - Yes
- **Delay** - 0 ms
- **Address** - 0.00

7.3.4 Binary Inputs – PDCIO and PBI

If the IPC402x device is configured to use PDCIO for extended I/O, see section 6.1, binary input subtabs are displayed showing the binary inputs of PDCIO and attached PBI modules. Configuration of these PDCIO objects is made in the same way as for other logical and physical inputs. The added objects are not described in details in this manual, for more information please refer to the user's manual of PDC2/PDCIO [4]. The PDC2/PDCIO manual also describes how to add and activate additional modules for binary inputs, PBI.

See section 7.3 Binary inputs for the general description of object settings.

The PDCIO/PBI objects have the following factory settings:

- **Type** - *Single point*
- **Settings – Blocked** - Yes
- **Settings – Negative** - No
- **Settings – Time tagged** - Yes
- **Delay** - 0 ms
- **Address** - See PDC2/PDCIO manual [4]

PDCIO can be configured for battery supervision, which adds logical input objects to the **PDCIO** tab. These objects have factory settings according to the PDC2/PDCIO manual [4] and the settings template for IPC402x [5].

7.4 Binary outputs – I/O-addressing – Binary Outputs

Settings for all binary outputs are available on the *Config – I/O-addressing – Binary Outputs* subtabs.

Unit	Communication	I/O addressing	Detector	NTP
	Binary inputs	Binary outputs	Analog inputs	
	Output 1-8	Detector 1		

On the *Output 1-8/12*¹ tab all physical outputs are listed.

Detector m contains binary outputs for the detector functions.

All binary outputs have the same parameter settings. Below is a general description.

For more information on each individual item, see the following chapters.

Parameter	Description	Range	Unit
Description	Brief descriptive name for the object.	-	-
Type	Type of object; <i>Single</i> or <i>Double</i> ² .	Single command, Double command	-
Settings – Blocked	The signal is blocked, i.e. no order or command is executed.	Yes or No	-
Settings – Direct Excute	The order is executed directly, ie no <i>select</i> is needed.	Yes or No	-
Pulse time [ms]	Number of milliseconds that the output signal should be high.	0 ... 65 535	ms
Address 8	Upper octet of the address. Decimal.	0 ... 255	-
Address 16	Lower octets of the address. Decimal.	0 ... 65 535	-

¹ If the device is an IPC4020exp4 or IPC4020exp5/6, there are additional physical binary outputs available.

² For Double command <OFF> this means that output relay *n* is closed and output relay *n+1* is opened. The command <ON> opens output relay *n* and closes output relay *n+1*.

7.4.1 Binary Outputs – Output 1-8/12

Settings for binary objects connected to physical outputs on the device, as well as the ACN button.

Only specific settings and differences to the normal are described below. See the beginning of this chapter for a general description of the various configuration options.

From factory, all objects are set as *single command* and the sequence *selected / executed*.

The objects have the following factory settings:

- **Type** - *Single command*
- **Settings - Blocked** - No
- **Settings – Direct Execute** - No
- **Pulse time** - 100 ms (200 ms fixed pulse time for object Ack)

Settings – Output 1-8/12:

Parameter	Description	Factory value address lower octets ¹
Ack	Object linked to the ACN button on the front panel. Can only have the type <i>single command</i> . Pulse time cannot be changed, fixed time of 200 ms.	21000
Output <i>n</i>	Object linked to physical output <i>n</i> .	21000+ <i>n</i>
Output 8	Object linked to physical output 8. Can only have the type <i>single command</i> .	21008
Output 8 + <i>n</i>	Object linked to physical output 8 + <i>n</i> (<i>n</i> = 1-3) of IPC4020exp4/5/6.	21008+ <i>n</i>
Output 12	Object linked to physical output 12 of IPC4020exp4/5/6. Can only have the type <i>single command</i> .	21012

¹ The upper octet has always factory setting 0.

7.4.2 Binary Outputs – Detector *m*

Settings for binary outputs linked to customer specific functions.

IPC402x has a number of logical outputs that can be used to activate and control various customized functions. In the standard version, there are no functions associated with these objects. However, they are visible via the web interface and a brief general description is therefore made here.

See the beginning of this chapter for a general description of the various configuration options.

From factory, all objects are set as a *single command* and the sequence *selected / executed*.

The objects have the following factory settings:

- **Type** - Logical output 1: *Double command*
- Logical output 2-13: *Single command*
- **Settings – Blocked** - Yes
- **Settings – Direct Execute** - Yes
- **Pulse time** - 100 ms

Since the items are not used, they are set to **Blocked** upon delivery.

Inställningar – Detector *m*:

Parameter	Description	Factory value address lower octets ¹
Logical output <i>n</i>²	Logical object for controlling customized functions.	21 <i>m</i> 00+ <i>n</i>

7.4.3 Binary Outputs – PDCIO and PBO

If the IPC402x device is configured to use PDCIO for extended I/O, see section 6.1, binary output subtabs are displayed showing the binary outputs of PDCIO and attached PBO modules. Configuration of these PDCIO objects are made in the same way as for other logical and physical outputs. The added objects are not described in details in this manual but are listed in the user's manual of PDC2/PDCIO [4]. The PDC2/PDCIO manual also describes how to add and activate additional modules for binary outputs, PBO.

See section 7.4 Binary outputs – I/O-addressing – *Binary Outputs* for the general description of output object settings.

The PDCIO/PBI objects have the following factory settings:

- **Type** - *Single command*
- **Settings – Blocked** - Yes
- **Settings – Direct Execute** - No
- **Pulse time** - 100 ms
- **Address** - See PDC2/PDCIO manual [4]

¹ *m* = 1 – 6 depending on detector number.

² Logical output 1: RECL OFF/ON, Auto reclosing deactivate / activate (option).

PDCIO can be configured for battery supervision, which adds logical output objects to the **PDCIO** tab. These objects have factory settings according to the PDC2/PDCIO manual [4] and the settings template for IPC402x [5].

7.5 Analog Inputs (I/O-addressing – Analog Inputs)

Settings for all analog inputs can be found in the *Config - I / O addressing - Analog Inputs* subtabs:

Unit	Communication	I/O addressing	Detector	NTP
Binary inputs		Binary outputs	Analog inputs	
Internal	Detector 1			

The *Internal* tab contains internal analogue system signals.

Detector m lists analog signals from the detector functions.

All analog signals have the same setting options. Below is a general description.

For more information on each individual item, see the following tab descriptions.

Parameter	Description	Range	Unit
Description	Brief descriptive name for the object.	-	-
Type	Type of analogue object; Different formats and scaling. ¹	Normalized [0–100 %], Normalized [0–120 %], Floating point [SI], Scaled [SI*1], Scaled [SI*10], Scaled [SI*100]	-
Settings – Blocked	The signal is blocked, i.e. no value / status is sent to the remote end. Also applies to "interrogation" (status request).	Yes or No	-
Settings – Timetagged	The signal is timestamped upon change. The time is also sent to the remote end.	Yes or No	-
Settings – Cyclic	The signal is sent using cyclic transmission	Yes or No	-
Deadband [%]	Deadband - indicates how much change is needed for a new value to be sent to the remote end. ¹⁾		%
Address 8	Upper octet of the address. Decimal.	0 ... 255	-
Address 16	Lower octets of the address. Decimal.	0 ... 65 535	-

¹ For a detailed description of what the different types provide regarding format, scaling and how the deadband is defined, see descriptions in the following text.

7.5.1 Analog Inputs – Internal

Settings for internal analog objects of the device.

Only specific settings and differences to the normal are described below. See the previous page for a general description of the configuration options.

Settings – Internal:

Parameter	Description	Factory value address lower octets
Unit temperature	Temperature measurement inside the device. Default: <ul style="list-style-type: none"> - Type: Float [SI] - Blocked: No - Time tagged: No - Cyclic: No - Deadband: 5.0 % 	3001
DAT3012 temperature 1	Object linked to temperature input 1 of DAT3012. Default: <ul style="list-style-type: none"> - Type: Float [SI] - Blocked: Yes - Timetagged: No - Cyclic: Nej Deadband: 100.0 %	0
DAT3012 temperature 2	Object linked to temperature input 2 of DAT3012. Default: <ul style="list-style-type: none"> - Type: Float [SI] - Blocked: Yes - Timetagged: No - Cyclic: Nej Deadband: 100.0 %	0

Type and Deadband – Internal:

Object	Type / Deadband	Description
Unit temperature	Normalized [0-100 %]	Normalized to 100 degrees Celsius.
	Normalized [0-120 %]	Normalized to 120 degrees Celsius.
	Float [SI]	Floating point corresponding to Celsius degrees.
	Scaled [SI*1]	Integers corresponding to Celsius degrees.
	Scaled [SI*10]	Integers corresponding to 0.1 Celsius degrees
	Scaled [SI*100]	Integers corresponding to 0.01 Celsius degrees.
Unit temperature	Deadband [%]	Set as a percentage of 100 degrees Celsius.

7.5.2 Analog Inputs – Detector *m*

This subtab contains settings for analog inputs connected to detector functions.

See chapter 7.5 Analog Inputs (I/O-addressing – Analog Inputs) for a general description of the configuration options.

Objects 1-4 and 6-7 in the table below have the following factory settings:

- **Type** - *Float [SI]*
- **Settings – Blocked** - No
- **Settings – Time tagged** - No
- **Settings – Cyclic** - No
- **Deadband** - 10.0 % (except object Neutral Current)
- 1.0 % (object Neutral Current)

The objects Max Fault Current and Fault Phase do not use deadband, and Fault Phase is of type **Scaled [SI*1]**. Max Fault Current is recalculated upon detected overcurrent, and Fault Phase is updated when the functions for overcurrent or directional earth fault react.

Current values are reflecting primary values.

If Cyclic transmission is activated for an object, the object will be updated spontaneously also when its value is outside the deadband. If no spontaneous transmission is desired, the deadband must be set to a high value.

For more information on the detector functions and the objects see chapter 8.

Settings – Detector *m*:

Object	Description	Factory value address lower octets ¹
L1 Current	Measured current (rms) at input L1 / Ia.	3m01
L2 Current	Measured current (rms) at input L2 / Ib.	3m02
L3 Current	Measured current (rms) at input L3 / Ic.	3m03
Neutral Current	Calculated residual current 3I0 (rms).	3m04
Max Fault Current	Maximum fault current (rms), I >>	3m05
Max Current	Maximum current (rms).	3m06
Average Current	Average current value (rms), 15 min.	3m07
Fault Phase	Faulty phase / phases. The following values can be sent: - 0,1,2,3,12,13,23,123 Can only be of the types: - "Float [SI]" or "Scaled [SI*1]"	3m08

¹ *m* = 1, 2 or 3 depending on the detector.

Type and deadband – *Detector m*:

Object	Type / Deadband	Description
Ly Current	Normalized [0-100 %]	Normalized primary current according to reference value on tab I/O Settings. Example: Reference value = 300/1 Value 0 ⇔ 0 A Value 1.0 ⇔ 300 A
	Normalized [0-120 %]	Normalized primary current according to reference value on tab I/O Settings times 1.2. Example: Reference value = 300/1 Value 0 ⇔ 0 A Value 1.0 ⇔ 360 A
	Float [SI]	Primary current in Amperes, as floating point.
	Scaled [SI*1]	Primary current in Amperes, as integer.
	Scaled [SI*10]	Primary current in 0.1 Amperes, as integer.
	Scaled [SI*100]	Primary current in 0.01 Amperes, as integer.
Ly Current	Deadband [%]	Set as a percentage of to reference value on tab I/O Settings. Example: Reference value = 300/1 1 % ⇔ 3 A
Neutral Current	Type	Identical to "Ly Current"
	Deadband	Identical to "Ly Current"
Max Fault Current	Float [SI]	Primary current in Amperes, as floating point.
	Scaled [SI*1]	Primary current in Amperes, as integer.
	Deadband [%]	Not used. Sent upon detected overcurrent (OC).
Max Current	Type	Identical to "Lx Current" ovan.
	Deadband	Identical to "Lx Current" ovan.
Average Current	Type	Identical to "Lx Current" ovan.
	Deadband	Identical to "Lx Current" ovan.
Fault Phase	Float [SI]	Faulty phase, as floating point.
	Scaled [SI*1]	Faulty phase, as integer.
	Deadband	Not used. Sent upon detected fault (OC/EF).

7.5.3 Analog Inputs – PDCIO and PAI

If the IPC402x device is configured to use PDCIO for extended I/O, see section 6.1, analog input subtabs are displayed showing the analog inputs of PDCIO and attached PAI modules. Configuration of these PDCIO objects is made in the same way as for other logical and physical analog inputs. The added objects are not described in details in this manual, for more information please refer to the user's manual of PDC2/PDCIO [4]. The PDC2/PDCIO manual also describes how to add and activate additional modules for analog inputs, PAI.

See section 7.5 Analog Inputs (I/O-addressing – Analog Inputs) for the general description of object settings.

The PDCIO/PAI objects have the following factory settings:

- **Type** - *Float [SI]*
- **Settings – Blocked** - Yes
- **Settings – Time tagged** - No
- **Settings – Cyclic** - No
- **Deadband** - 10.0 %
- **Address** - See PDC2/PDCIO manual [4]

PDCIO can be configured for battery supervision, which adds logical input objects to the tab. These objects have factory settings according to the PDC2/PDCIO manual [4] and the settings template for IPC402x [5].

In addition, there are thresholds for temperature alarms on the subtab **Analog Inputs – PDCIO**. The temperature measured by an external temperature sensor is compared to these settings and alarms are generated if the temperature exceed/fall short of the thresholds. The alarm objects are defined on the **Binary Inputs – PDCIO** subtab.

Parameter	Description	Range	Factory value	Unit
PT100 High level 1	Alarm level high temperature level 1	1..1 000	100	°C
PT100 High level 2	Alarm level high temperature level 2	1..1 000	150	°C
PT100 Low level	Alarm level low temperature	-40..+20	-10	°C

8 Detector Functions

8.1 General

IPC402x contains the following detector functions:

- Overcurrent - detects short circuit or overload
- Earth fault Protrol - patented method for sensitive detection of solid and intermittent earth faults
- Earth fault non-directional – residual current based detection
- Phase break - for detection of the loss of a phase

The fault detector measures the phase currents. Isolation between detector and the secondary current circuit of the primary current transformer is provided by current transformers. The sampling frequency of the phase currents is 2 kHz.

Protrol's method for earth fault detection is of transient measuring nature, which means that it is both fast and sensitive. Fast means that the method works safely for both high impedance as well as transient and arcing faults. The method is based on analysing the change of the phase currents when an earth fault occurs. Detection of an earth fault means that the fault is downstream of the measuring point in a radial network, or that a fault current has passed the measuring point, i.e., true fault pass-through detection. Indirectly, this means that the direction of the fault can be identified by measuring phase currents only, without the need of polarizing zero-sequence voltage.

The method works very safely for all types of networks from directly grounded to isolated. In particular, this means that for an impedance grounded network, the compensation degree has no significance, and for an isolated network, the natural unbalance between the phases in principle can be infinite. It works just as well.

8.2 Detection states

The earth fault detection sequence goes through discrete states. These states can be seen in the transient fault recording (chapter 10). For each state, an evaluation is made if certain conditions are met to proceed to the next state. If these conditions are not met, a controlled return to the basic state is made.

0 IDLE – This is the basic state. The detector continuously evaluates any changes in the residual current, I_N .

2 TRIG – An earth fault somewhere in the network is triggered by detecting a sudden change of I_N . The size of the change is related to the sensitivity, the smaller the change, the higher the impedance of the earth fault. During a short period after TRIG, the nature of the error is evaluated. Depending on the result, the state changes to either RESET, EVAL-T, or EVAL-A.

3 EVAL-T – In this state, supplementary calculations are made especially for high impedance faults. From this state, the detector always continues to EVAL-A.

4 EVAL-A – State to determine whether the detector should go to START or RESET.

5 START – Here, a timer for the set time delay is started. The detector proceeds to the DETECT or TRIP states if the changed I_N exists after the set time. The state will return to RESET if the condition is not met.

6 DETECT/TRIP – This state means that a fault has been detected. Controlled return to IDLE via RESET will follow.

8 REIGNITION – This state means the same as DETECT but indicates that the fault is reigniting or arcing.

1 RESET – The detector will temporarily and as short as possible be in this state for the return to IDLE to be controlled.

Similar states also exist for overcurrent, non-directional earth fault and phase interruption. Only the overcurrent detection states for stage 1 are displayed in the transient fault recording:

0 IDLE

2 START

4 DETECT/TRIP

The *State* signal in the transient fault recording file contains information on the state of both earth fault and overcurrent. The state signal is an 8-bit value where the lower nibble indicates the state of the earth fault detector and the upper one indicates the state of overcurrent one. For example, the value 34 decimals (22 hexadecimal) means that ground fault has state 2-TRIG and overcurrent 2-START.

8.2.1 Evaluation of Earth Faults

See the example below showing a solid earth fault and the corresponding state changes during the evaluation process.

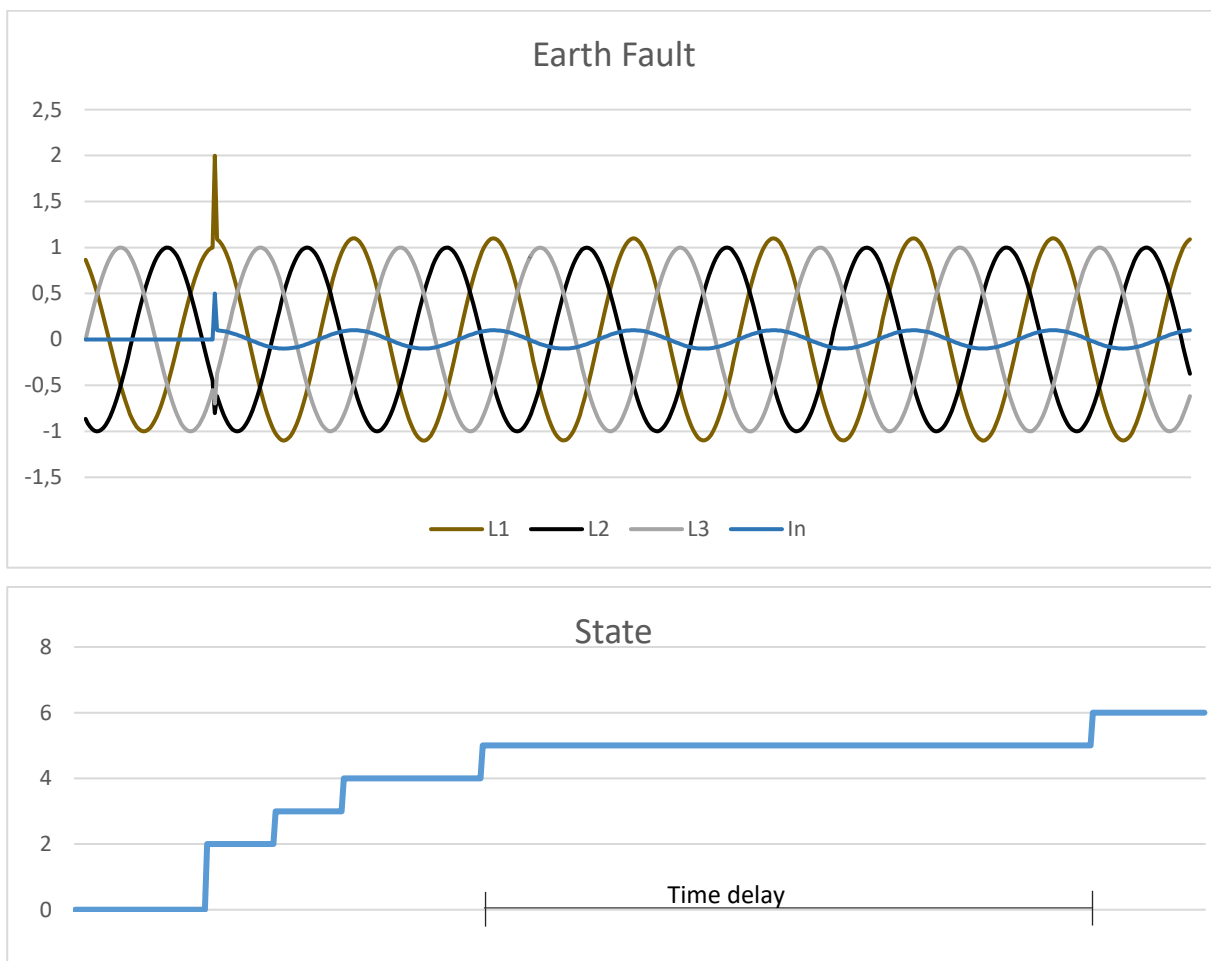

Figure 10. States during the evaluation of a solid earth fault.

8.2.2 Evaluation of Transient and Arcing Faults

An arcing earth fault is characterized by its transient nature. It extinguishes and then returns with a new transient after a certain time or with a certain frequency. If the time delay is short enough, a single transient may be sufficient for the detector to go to the *TRIP* state. If an error occurs and the detector reaches the *START* state, the *reignition* timer is started. If the fault returns within the set reignition time, the detector will indicate *TRIP* immediately when the *START* state is reached. Thus, it does not wait for the normal time delay between *START* and *TRIP* to expire. Two consecutive starts within a certain time is evaluated as an arcing fault. The method ensures that an arcing error does not start and reset repeatedly.

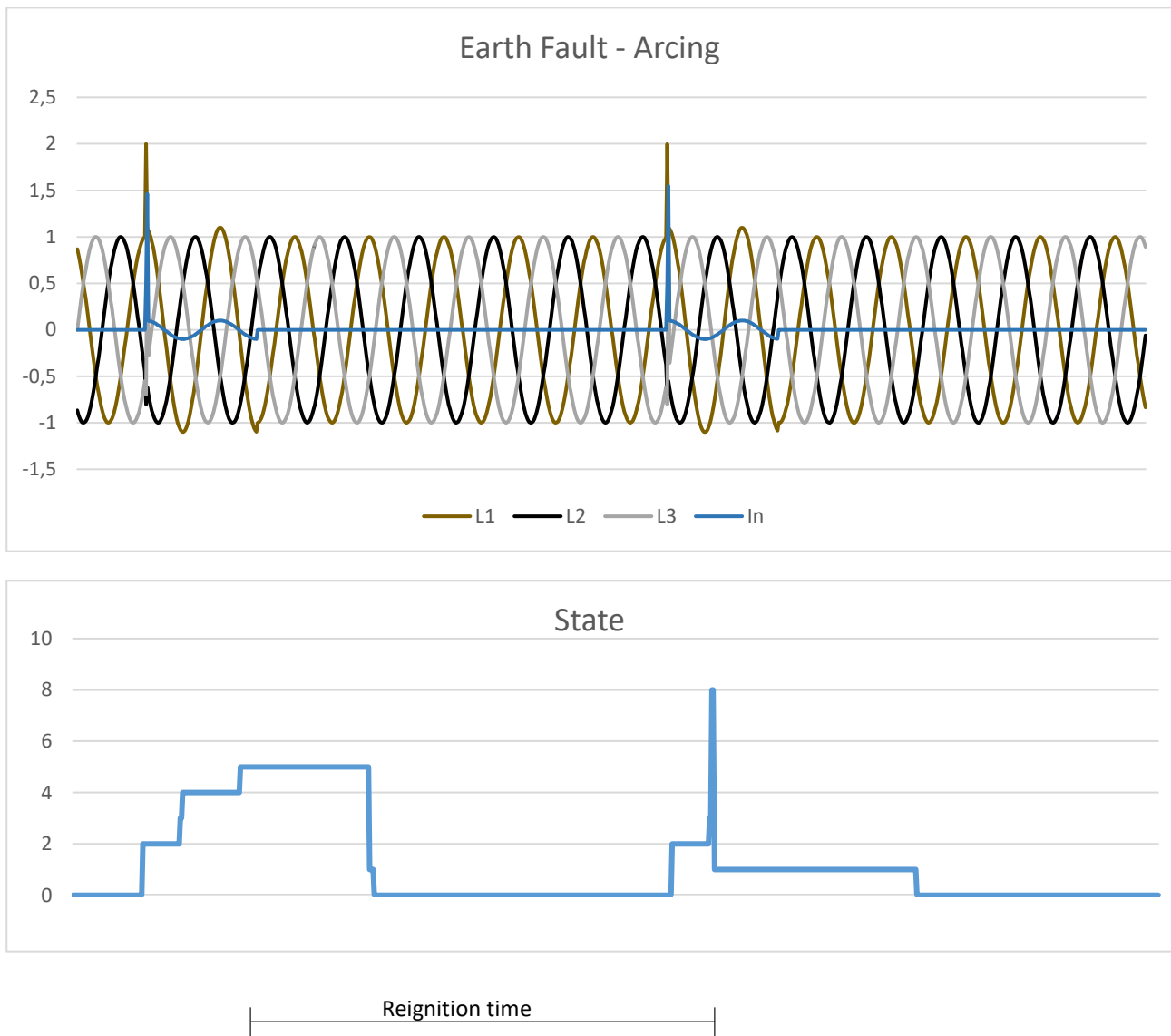

Figure 11. Earth fault with arcing characteristics – after the second “START” the detector progresses immediately to state TRIP.

8.3 Settings - Common

Detector function settings can be found on the website on tab *Config/Detector*. Here are two or four subtabs found, *Common*, *Detector 1*, *Detector 2*, *Detector 3* etc.

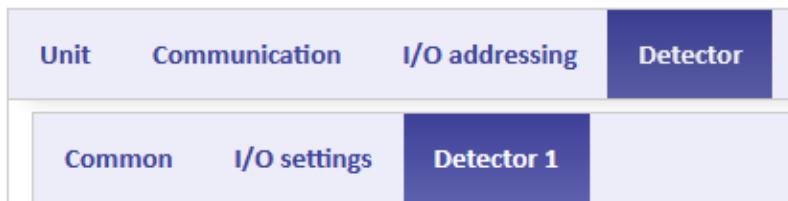

Figure 12. Settings for the *Detector* functions.

Settings – Auto acknowledge

Parameter	Description	Range	Factory value	Unit
Enable	Activation of automatic acknowledge.	Yes or No	Yes	-
Auto ack delay	Time for automatic acknowledge after fault detection.	0..48	4	hour ¹

The function for transient fault recordings is described in detail in chapter 10. There are limitations in the number of transient fault recordings that can be stored in runtime memory. If there is a need to ensure that there is always space for a new disturbance recording, the parameter **Enable immediate ack** can be checked. Observe that previous recordings can be deleted if the detector restarts due to new events.

Inställningar – TFR functions

Parameter	Description	Range	Factory value	Unit
Enable immediate ack	Activation of automatic acknowledge of TFR.	Yes or No	Nej	-
Enable TFR at EF trig	Aktivering av störningskrivare vid EF TRIG	Ja eller Nej	Nej	-
Pretrigger	Time for the first data point of the record.	1.. 950	140	ms

Specialist settings

Parameter	Description	Range	Factory value	Unit
Post Trip Blocking Time	Time for blocking of detector functions after fault detection	0..1 000 000	2 000	ms
Test qualifier	Parameter for test	0..4294967295	0	-

When the option Full automation (FLISR) is activated, additional specialist settings will appear. They are described in a separate User's Manual.

¹ The unit can be seconds, minutes, or hours. Maximum time is 48 h.

8.4 Settings - I/O Settings

Analog inputs are used to digitize signals that represent various primary values. There are a variety of settings that can condition these input signals. These settings are briefly described below.

Parameter property	Description	Range
Scale	Scaling factor, from secondary to primary values (ratio).	0..2 000
Decimals	Number of decimals for the value presented in the web interface.	0..3

Specialist settings

Parameter property	Description	Range
Offset	Offset added to the secondary value before scaling it.	0.000..1.000
Ref value	The reference value represents 100% of the nominal primary value, and is used for the calculation of deadbands. For phase currents the reference value is linked to the Scale value.	0..2 000
Unit - prefix¹	E.g., m(illi), k(ilo) or M(ega).	-, m, k, M
Unit - unit	SI unit of the primary signal	-, A, W, VA, Hz, degC

Settings – I/O Settings

Signal	Description	Range	Factory value	Unit	No of decimals
Detector m Ly current	Ratio phase y, detector x	1..2 000	300 ²	A	1

Other factory default settings for the number of decimals are according to the following table.

Signal	Description	Factory value No of decimals
Unit temperature	See section 7.5.1	1
Detector m Neutral Current	See section 7.5.2	2
Detector m Max fault current	See section 7.5.2	0
Detector m Max current	See section 7.5.2	1
Detector m Average current	See section 7.5.2	1
Detector m Fault phase	See section 7.5.2	0

¹ Does not affect the amplitude of the input signal.

² Ratio Primary/Secondary current. Also applies to display of other currents.

8.5 Detector Settings – *Detector n*

8.5.1 Overcurrent

IPC402x has two overcurrent steps that operate independently of each other. Overcurrent **Enable** means that both steps are activated. The start signal is common. This means that *START* overcurrent is generated by either step 1 or step 2 starting. The overcurrent function measures the RMS value of all phases. Inverse time characteristics can be activated for step 1 using the parameter **Enable**.

The *START* signal is generated if the current in a phase exceeds the set levels, **Level 1** or **Level 2**. *TRIP* overcurrent is generated after the set time delays, **Delay 1** or **Delay 2**. If the setting **Input qualifier** is selected to any input, 1-16, no *TRIP* output signal and message to remote control will be created until there is voltage on the selected input within set time, **Event delay**. However, the internal event is always generated.

If inverse time characteristics is used, **Delay 1** is ignored and is replaced with a calculated delay time according to IEC 60255,

$$t = TMS \times \left(\frac{k}{\left(\frac{I}{I_{Level\ 1}} \right)^\alpha - 1} \right)$$

Where **TMS** is a parameter of own choice and k and α are defined by the choice of inverse curve according to the following table.

Curve type	k	α
Standard inverse	0,14	0,02
Very inverse	13,5	1
Extremely inverse	80	2
Long inverse	120	1

If inverse time characteristics is chosen, step 1 starts at 105% of **Level 1**.

Settings – Overcurrent:

Parameter	Description	Range	Factory value	Unit
Enable	Overcurrent steps activated	Disabled Definite Standard inv Very inv Extremely inv Long inv	Disabled	-
Level 1	Overcurrent level step 1	0..10 000.0	500.0	A
Delay 1	Time delay between <i>START</i> and <i>TRIP</i> step 1	0..10 000	40	ms
TMS 1	Time multiplier at inverse time step 1	0.05..1.00	0.05	-
Level 2	Overcurrent level step 2	0..10 000.0	10 000.0	A
Delay 2	Time delay between <i>START</i> and <i>TRIP</i> step 2	0..10 000	10 000	ms
Event delay	Time delay for <i>TRIP</i> interlocked with input	0..25 000	0	ms
Input qualifier	Input for release of <i>TRIP</i>	0..16	0 (non)	-
Trip relay	<i>TRIP</i> output relay	0..8	0 (non)	-
Relay pulse	Pulse length of <i>TRIP</i> output signal	100..60 000	500	ms
Level 1 - set point address¹	Address for <i>Set point command</i> in accordance with IEC 60870-5-101/-104	0..16 777 214	0	-
Delay 1 - set point address	Address för <i>Set point command</i> in accordance with IEC 60870-5-101/-104	0..16 777 214	0	-

8.5.2 Earth Fault, General

The IPC402x devices have two types of earth fault detectors; Protrol's patented method, and a supplementary non-directional earth fault function that can be employed when switching onto faults. The non-directional function can also be used to detect fault connection, that a phase is missing or that one phase is connected with the wrong polarity. Both methods work independently of each other. Both will set the indication earth fault *START*.

8.5.3 Earth Fault Protrol

IPC402x initially triggers a ground fault detection sequence on a change in the zero-sequence system. The current **Level** corresponds to the zero-sequence current measured by the detector.

A *START* signal is generated if the detector reaches State 5, according to Section 8.2. Ground fault *TRIP* is generated after set time **Delay** or if immediately without delay if the reignition timer has been started by a previous transient. If the setting **Input qualifier** is selected to any input, 1-16, no *TRIP* output signal and message to remote control will be created until there is voltage on the selected input within set time, **Event delay**. However, the internal event is always generated.

¹ The device restarts 10 seconds after last Set point command.

Settings – Earth Fault Protrol:

Parameter	Description	Range	Factory value	Unit
Enable	Protrol earth fault function activated	Yes or No	No	-
Level	Earth fault current level	0.1..100.0	2.0	A
Delay	Time delay between <i>START</i> and <i>TRIP</i>	0..10 000	100	ms
Event delay	Time delay for <i>TRIP</i> interlocked with input	0..25 000	0	ms
Input qualifier	Input for release of <i>TRIP</i>	0..16	0 (non)	-
Trip relay	<i>TRIP</i> output relay	0..8	0 (non)	-
Relay pulse	Pulse length of <i>TRIP</i> output signal	100..60 000	500	ms
Reignition enable	Reignition feature activated	Yes or No	Yes	-
Reignition delay 1	Time window for reignition to be identified	0..25 000	2 500	ms
Level - set point address¹	Address for <i>Set point command</i> in accordance with IEC 60870-5-101/-104.	0..16 777 214	0	-
Delay - set point address	Adress für <i>Set point command</i> in accordance with IEC 60870-5-101/-104.	0..16 777 214	0	-

Specialist settings

Parameter	Description	Range	Factory value	Unit
Trig level	Trig level for earth fault – not possible to set	0.0..100.0	90% of Level	A
Asym level	Asymmetry level	1.0..1000.0	3.0	-
TPAD level	Alternative asymmetry level	1.0..1000.0	1.5	-
TPAD angle 1	Angle restriction 1	0.0..100.0	30.0	deg
TPAD angle 2	Angle restriction 2	90.0..270.0	150.0	deg
Early start	Alternative for the reignition function	0..2	0	-
Fast reset	Deactivation of fast reset i r.0.2.3	0..1	0	-
Minimum arcing time	Shortest time for reignition/arcing fault	0..25 000	0	ms

¹ The device restarts 10 seconds after last Set point command.

8.5.4 Non-Directional Earth Fault

Activation of non-directional earth fault can be selected as **Always** or only after closing of the circuit breaker, **Only at Close**. Closing or energization is detected using an input indicating ON, specified by the parameter **Input qualifier**, or by using the current change. The two alternative ways of detecting a closed circuit breaker work in parallel. The earth fault function is activated during a set time, parameter **Event delay**.

The non-directional earth fault function measures the residual current, $I_a + I_b + I_c$. The measurement method can be chosen between **RMS** and **Fundamental**. The latter means that only the fundamental harmonic is measured, since characteristic harmonics are suppressed.

START signal is generated when the sum current exceeds the set threshold, **Level**. **TRIP** earth fault is generated after the set time **Delay**.

Settings – Non-Directional Earth Fault:

Parameter	Description	Range	Factory value	Unit
Enable	Non-directional earth fault function activated	Never/ Always/ Only at close	Always	-
Level	Earth fault current level	0.1..500.0	10.0	A
Delay	Time delay between START and TRIP	0..10 000	100	ms
Event delay	Time delay for TRIP interlocked with input, alternatively time window for activation after closing of circuit breaker	0..25 000	0	ms
Input qualifier	Input for release of TRIP , alternatively input for ON indication for activation after closing of circuit breaker	0..16	0 (non)	-
Trip relay	TRIP output relay	0..8	0 (non)	-
Relay pulse	Pulse length of TRIP output signal	100..60 000	500	ms
Measurement type	Measurement method RMS or Fundamental	RMS/ Fundamental	RMS	-
Low level	Current level before for switch-on detection.	0.1..500.0	1.0	A
High level	Current level after for switch-on detection.	0.1..500.0	30.0	A

8.6 Phase Break

A phase break is identified as a failure of a phase without grounding. Typical scenario is the interruption due to a down fallen phase conductor that does not get in contact with ground. The following criteria must be met for phase interruptions to be detected:

- Residual current < **Low Level**
- Current in one of the phases < **Low Level**
- Current in the other two phases > **High Level**

When the three criteria at the same time have been fulfilled during the set time **Delay**, a phase break is detected. Phase breaks do not result in a start signal. Note that if a phase is missing but the two remaining have a phase difference of 120 degrees, there will be no phase break. Such a fault is indicated by a non-directional earth fault.

Settings – Phase Break:

Parameter	Description	Range	Factory value	Unit
Enable	Phase break function activated	Yes or No	No	-
Low Level	Max current for lost phase and residual current	0.1..1000.0	5.0	A
High Level	Min current level for healthy phases	0.1..1000.0	20.0	A
Delay	Time delay between <i>START</i> and <i>TRIP</i>	0..10 000	5 000	ms
Trip relay	<i>TRIP</i> output relay	0..8	0 (non)	-
Relay pulse	Pulse length of <i>TRIP</i> output signal	100..60 000	500	ms

8.6.1 Auto reclosing – OPTIONAL

Auto reclosing (AR - *RECL*) means that a delayed switch-on is ordered after a set delay initiated by a *TRIP* order has been issued by any of the overcurrent or earth fault protection functions. The AR – RECL sequence can be triggered by one or several functions. This option can be activated for one or three bays.

Activation of the function can be made at the device using a binary input or the ACN button. It can also be ordered by the remote control centre. The ACN button must be pressed 5 s before toggling takes place. Indication to and order from SCADA is configured as double point / double command, see *I/O-addressing/Binary inputs/Detector m/RECL OFF/ON* and *I/O-addressing/Binary outputs/Detector m/RECL OFF/ON*, respectively. These objects are blocked from factory.

Visual indication of AR OFF/ON can be chosen as follows:

AR for Detector 1 – outputs 1 – 8, however, always AUX-LED

AR for Detector 2 and 3 – outputs 1 – 8, and/or AUX-LED

After reclosure the function is always OFF. Reactivation can be done from SCADA but will always be done automatically by Acknowledge after a preset time or by pressing the ACN button. Also, a restart of the device inactivates AR. Manual switch-on of the circuit breaker blocks auto reclosure for 60 s.

The event log shows events for AR OFF/ON, AR started and AR executed: *RECL OFF*, *RECL ON*, *RECL Started*, *RECL Executed*.

Settings – Auto reclosing:

Parameter	Description	Range	Factory value	Unit
Enable	Choice of function that starts auto reclosing	OC/EF/NDEF	Disabled	-
Delay	Time delay for auto reclosing	500..60 000	30 000	ms
Reclosure relay	Output relay for reclosing (<i>ON</i> output)	0..8	0 (None)	-
Relay pulse	Pulse length of <i>ON</i> output signal	100..10 000	500	ms
Input ON/OFF	Input for local activation of auto reclosing	ACN, 1..16	ACN	-
Output indication	Output or LED for local indication OFF/ON	1..8, AUX LED	AUX LED	-

It is strongly recommended to use the Non-directional earth fault function with activation after switch-on to ensure safe detection of a permanent earth fault after the auto reclosure operation.

9 Event log and Site Manager

9.1 Event log – *Event log*

The event registration that logs events in the device, *Event log*, can be found in the web interface under the *Status* tab. Here, both internal events and events generated by detector functions are shown. An event has four different fields:

- **Timestamp** - time marking
- **Type** - type of event can be *Error*, *Warning*, *Info* or *Debug*
- **Text** - description of the event
- **Extra information** - four fields for extra information mainly for internal use

In the example in Figure 13, additional diagnose information is displayed. For the *EF Detected* event, the first digit tells which detector has started. In this case, it is *Detector 1*. The second digit of the *EF Detected* is the *State*. Here it is 8 which means that it was the reignition function that detected the fault. Third digit for *EF NONDIR Detected* or *EF Detected* indicates that faulty phase is L2. For overcurrent, there are also options 12, 13, 23 or 123, which show which phases are involved.

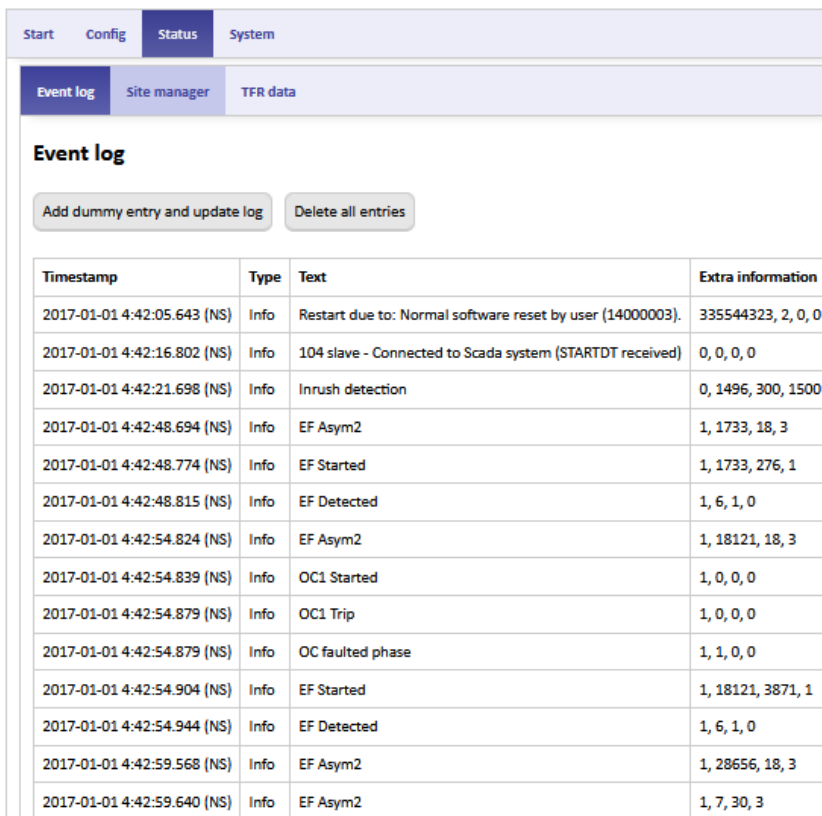

Timestamp	Type	Text	Extra information
2017-01-01 4:42:05.643 (NS)	Info	Restart due to: Normal software reset by user (14000003).	335544323, 2, 0, 0
2017-01-01 4:42:16.802 (NS)	Info	104 slave - Connected to Scada system (STARTDT received)	0, 0, 0, 0
2017-01-01 4:42:21.698 (NS)	Info	Inrush detection	0, 1496, 300, 1500
2017-01-01 4:42:48.694 (NS)	Info	EF Asym2	1, 1733, 18, 3
2017-01-01 4:42:48.774 (NS)	Info	EF Started	1, 1733, 276, 1
2017-01-01 4:42:48.815 (NS)	Info	EF Detected	1, 6, 1, 0
2017-01-01 4:42:54.824 (NS)	Info	EF Asym2	1, 18121, 18, 3
2017-01-01 4:42:54.839 (NS)	Info	OC1 Started	1, 0, 0, 0
2017-01-01 4:42:54.879 (NS)	Info	OC1 Trip	1, 0, 0, 0
2017-01-01 4:42:54.879 (NS)	Info	OC faulted phase	1, 1, 0, 0
2017-01-01 4:42:54.904 (NS)	Info	EF Started	1, 18121, 3871, 1
2017-01-01 4:42:54.944 (NS)	Info	EF Detected	1, 6, 1, 0
2017-01-01 4:42:59.568 (NS)	Info	EF Asym2	1, 28656, 18, 3
2017-01-01 4:42:59.640 (NS)	Info	EF Asym2	1, 7, 30, 3

Figure 13. *Event log for IPC402x.*

At the top there is a button to generate a *dummy* event for test purposes. It is also possible to empty the list.

9.2 Site Manager

Site manager is found in the web interface on the **Status** tab. **Site Manager** provides an overview of real time data and the possibility to locally clear LED indications or reset measurement values.

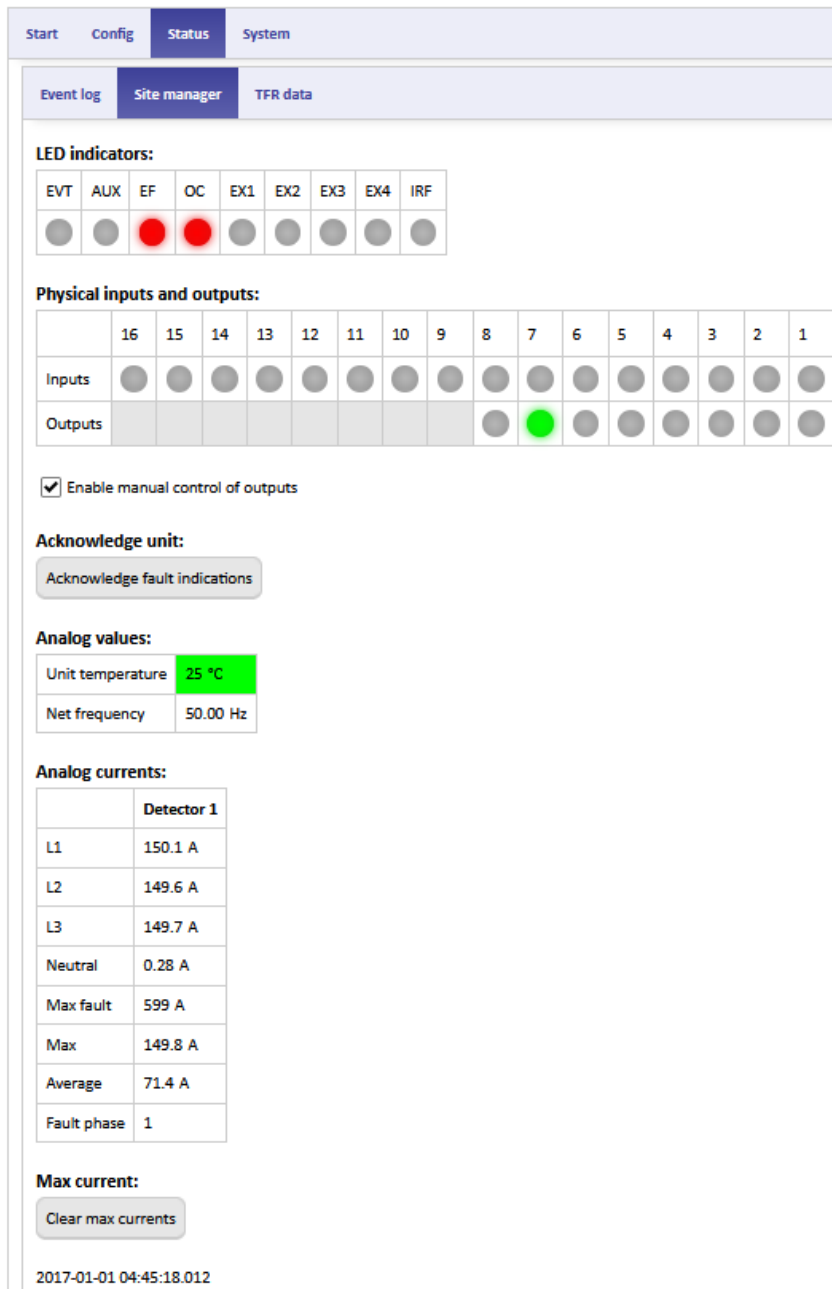

Start Config **Status** System

Event log **Site manager** TFR data

LED indicators:

EVT	AUX	EF	OC	EX1	EX2	EX3	EX4	IRF
●	●	●	●	●	●	●	●	●

Physical inputs and outputs:

	16	15	14	13	12	11	10	9	8	7	6	5	4	3	2	1
Inputs	●	●	●	●	●	●	●	●	●	●	●	●	●	●	●	●
Outputs									●	●	●	●	●	●	●	●

Enable manual control of outputs

Acknowledge unit:

Acknowledge fault indications

Analog values:

Unit temperature	25 °C
Net frequency	50.00 Hz

Analog currents:

	Detector 1
L1	150.1 A
L2	149.6 A
L3	149.7 A
Neutral	0.28 A
Max fault	599 A
Max	149.8 A
Average	71.4 A
Fault phase	1

Max current:

Clear max currents

2017-01-01 04:45:18.012

Figure 14. Site manager for IPC4020.

Please note that Site manager will adjust to the type of IPC402x device that is used and on what options that are activated.

The table below describes the indicators on the *Site Manager* tab.

Indicator	Description
EVT	Yellow diode indicating that there is an unsent telegram in the queue for slave transmission on the system interface
AUX	Yellow diode that normally indicates that the device is handling a frequency deviation
EF	Red diode indicating that an earth fault has been detected
OC	Red diode indicating that an overcurrent has been detected
EX1	Yellow diode indicating that Detector 1 has identified a fault
EX2	Yellow diode indicating that Detector 2 has identified a fault – applies to expanded device
EX3	Yellow diode indicating that Detector 3 has identified a fault – applies to expanded device
EX4	Yellow diode that in normal configuration indicates start fault detection, detector 1-3
IRF	Red diode that indicates internal fault
Inputs 1 - 8/10/16	Yellow indicator for active input.
Outputs 1 – 3/8	Yellow indicator for active output.

There are additional indicators if PDCIO is connected.

Indicator	Description
IRF	Red indicator that signals internal fault.
EVT	Yellow diode indicating that there is an unsent telegram in the queue for slave transmission on the slave interface
Input 1 – 13	Yellow indicator for active input.
Output 1 - 8	Yellow indicator for active output.
Expected	Green indicator that signals that PDCIO is configured for PBIx, PBOx or PAIx
Found	Green indicator that signals that PDCIO has found PBIx, PBOx and PAIx
PBI Input 1 – 15	Yellow indicator for active input of PBIx.
PBO Output 1 - 12	Yellow indicator for active output of PBOx.
PAI Input 1 – 8	Yellow indicator for active input of PAIx.

If PDCIO is configured for battery supervision, there are two additional indicators.

Indicator	Description
Status	Green/Red indicator which indicates battery fault.
Test in progress	Yellow indicator which indicates that battery test is in progress.

On the **Site manager** tab, the status of the following is displayed:

- Indications - the status of each LED is mirrored.
- Temperature - measured inside the device and displayed with an offset of -15 degrees in standard design. E.g., if the unit measures 43 degrees, the value 28 is displayed.
- Current values, primary values.
 - Phase currents and residual current.
 - Max fault current.
 - Max current tracking pointer - resets with the **Clear max currents** button.
 - 15 minutes mean value of minimum phase current.
- Faulty phase(s) for last registered fault.
- Current time - *RTC time*.

The **Acknowledge fault indications** button works just like the physical button on the device. Note that the value *Max current* is not reset.

Site manager is typically used to check the device status via the Ethernet interface and in conjunction with commissioning to obtain current values. A good way to verify that all phase currents are correctly connected is, for example, to read the amplitudes. If they are equal and the sum current at the same time is small, the connection is likely to be correct.

There is a checkbox that enables activation of the outputs via the web interface. To activate an output, simply click on its LED symbol. It then lights up and closes the relay output for 3 seconds. Manual control of outputs is stopped at logout.

10 Transient Fault Recorders – TFR

The transient fault recorder saves the current phases and *State* during 1 s with the resolution 2 000 Hz, including the time that is specified by the parameter *Pretrigger*. See chapter 8.2. for more details on *State*. Disturbance recorder data is found on subtab *Status/TFR data*. If there are more than one detector, one file per detector is saved regardless of which one that triggers the recording. To download the interference file, simply click on the button *Detector 1*, *Detector 2* or *Detector x*. Depending on the browser settings, you can select the file name and destination for the download.

The *Type* column specifies what triggered the file to be saved. For example, the earth fault function may have started. The following events trigger the transient fault recorder:

- *START* overcurrent
- *START* earth fault
- *START* non-directional earth fault
- Manual trigger by pressing **Capture active live data**. See Figure 15.

The rightmost column contains a button, **Acknowledge**. The purpose of the function is that non-acknowledged disturbances files should not be overwritten and valuable information lost. A disturbance file can be acknowledged in several ways:

1. Press the button for the respective interference in the *TFR data* subtab. Only this specific disturbance is acknowledged.
2. Press the physical button on the IPC device. All disturbances are acknowledged.
3. By automatic acknowledgment after some time, a setting on the *Config/Detector/Common* subtab. All disturbances are acknowledged.
4. By sending a telegram, *single command* to the device, addressing *Acknowledge*, binary outputs. All disturbances are acknowledged.

A maximum of ten disturbances records are saved. Only a disturbance record that is acknowledged can be discarded. The oldest acknowledged disturbance record will be next to be discarded. This means that after an acknowledgment, IPC402x is always ready to register a new disturbance file.

The disturbance records are stored in non-volatile memory. It is possible to erase individual or all disturbance records manually, i. e., after commissioning and/or testing.

Earlier versions of IPC4020 were not able to store disturbance records in non-volatile memory. Such devices can record four disturbance files, and they are lost upon restart of the device.

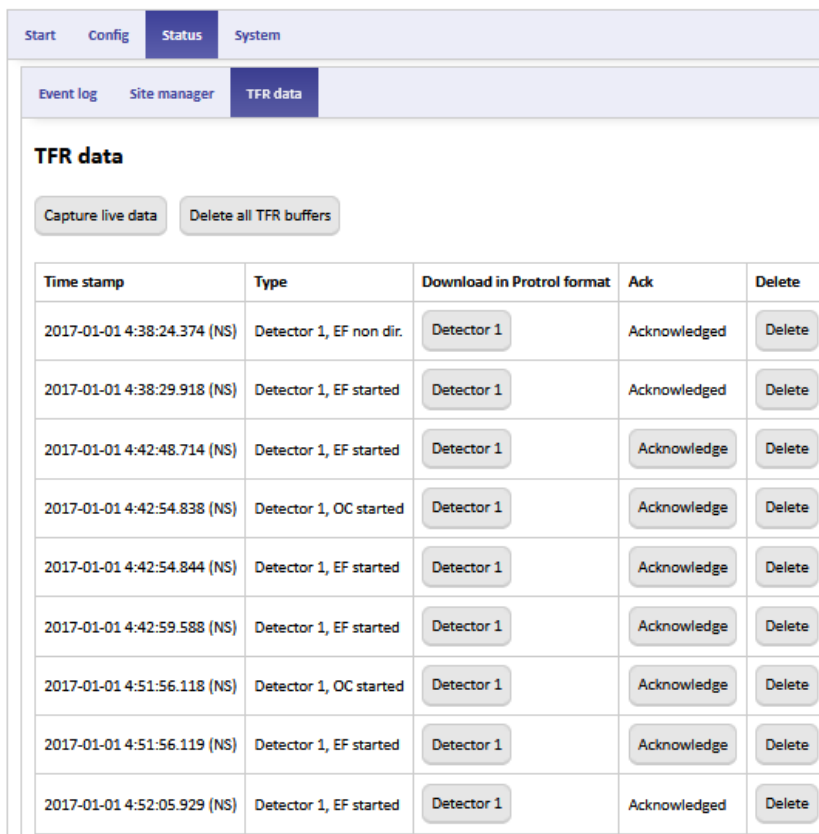

Time stamp	Type	Download in Protrol format	Ack	Delete
2017-01-01 4:38:24.374 (NS)	Detector 1, EF non dir.	Detector 1	Acknowledged	Delete
2017-01-01 4:38:29.918 (NS)	Detector 1, EF started	Detector 1	Acknowledged	Delete
2017-01-01 4:42:48.714 (NS)	Detector 1, EF started	Detector 1	Acknowledge	Delete
2017-01-01 4:42:54.838 (NS)	Detector 1, OC started	Detector 1	Acknowledge	Delete
2017-01-01 4:42:54.844 (NS)	Detector 1, EF started	Detector 1	Acknowledge	Delete
2017-01-01 4:42:59.588 (NS)	Detector 1, EF started	Detector 1	Acknowledge	Delete
2017-01-01 4:51:56.118 (NS)	Detector 1, OC started	Detector 1	Acknowledge	Delete
2017-01-01 4:51:56.119 (NS)	Detector 1, EF started	Detector 1	Acknowledge	Delete
2017-01-01 4:52:05.929 (NS)	Detector 1, EF started	Detector 1	Acknowledged	Delete

Figure 15. TFR data subtab of the web interface.

TFR data is saved in the same basic format as for IPC401x. Data can thus be displayed by the same tool, see [3]. In addition, there is a modern tool for viewing Ensto Protrol's disturbance recordings, Protrol TFR Plotter.

For conversion to COMTRADE there is a special tool, available on Protrol's web page. Also, files from IPC401x can be converted.

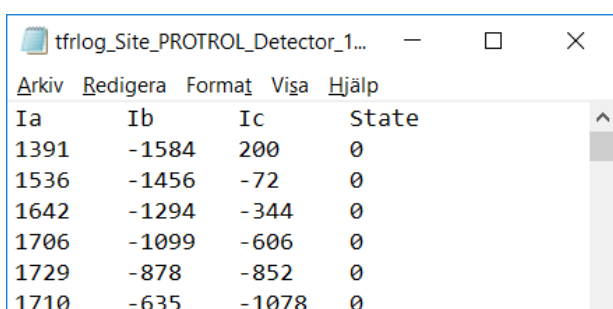

Ia	Ib	Ic	State
1391	-1584	200	0
1536	-1456	-72	0
1642	-1294	-344	0
1706	-1099	-606	0
1729	-878	-852	0
1710	-635	-1078	0

Figure 16. The log file with TFR data – phase currents and State.

At the end of the log file there is additional information to obtain traceability during error analysis. Here can be found, among other things, version number, detector type, station name and scaling information. See Figure 17.

Some of the information is necessary for the conversion to COMTRADE to work. This applies to frequency, sampling frequency, CT ratio, resolution (RatedBinary) and time stamp.

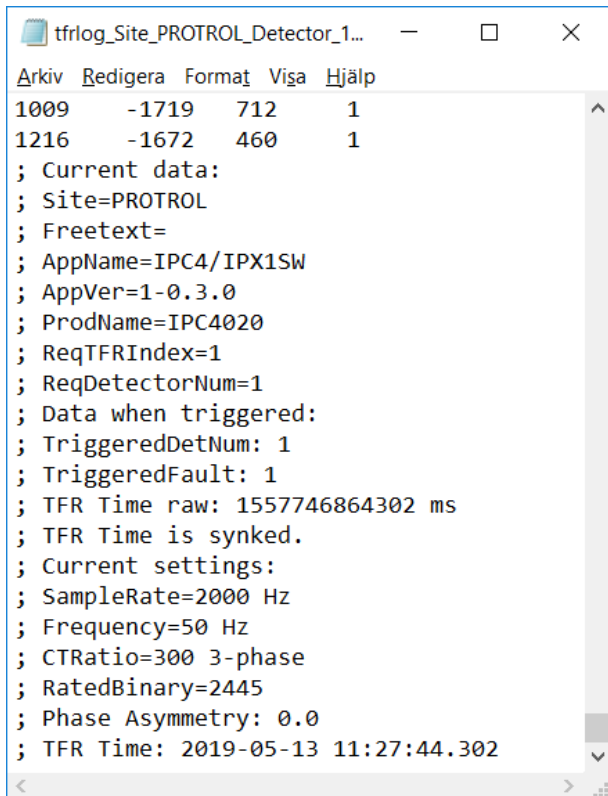

```
Arkiv Redigera Format Visa Hjälp
1009 -1719 712 1
1216 -1672 460 1
; Current data:
; Site=PROTROL
; Freetext=
; AppName=IPC4/IPX1SW
; AppVer=1-0.3.0
; ProdName=IPC4020
; ReqTFRIndex=1
; ReqDetectorNum=1
; Data when triggered:
; TriggeredDetNum: 1
; TriggeredFault: 1
; TFR Time raw: 1557746864302 ms
; TFR Time is synked.
; Current settings:
; SampleRate=2000 Hz
; Frequency=50 Hz
; CTRatio=300 3-phase
; RatedBinary=2445
; Phase Asymmetry: 0.0
; TFR Time: 2019-05-13 11:27:44.302
```

Figure 17. TFR log file – data at the end of the file.

The COMTRADE converter is shown in Figure 18 beneath.

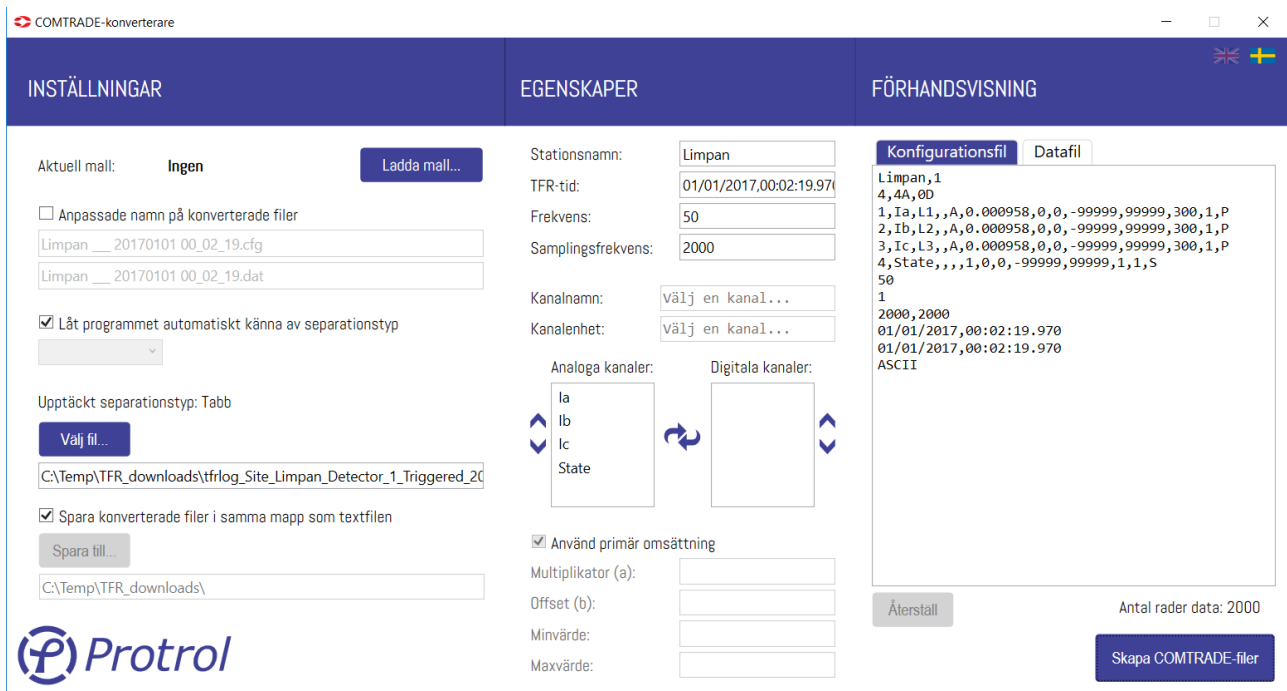

Figure 18. COMTRADE converter.

- Upload a stored TFR file from the test device or select a previously uploaded file.
- Specify where to save a converted file. By default, it is saved in the same directory as the original data. It is possible to change file names if desired. The tool recognizes the type of data separation, eg loss or comma. Separation type can also be specified.
- When the file is selected, the configuration file and data file are displayed to the right. Change any input, scaling, labels, etc., if necessary.
- Convert by clicking **Create COMTRADE files**.

11 Upgrade of Firmware

11.1 IPC402x

Prepare upgrade by saving a local copy of settings. The procedure is described in Chapter 0.

Chose a *Bundle file* for firmware upgrade of the IPC402x (“unit”) on the **System** tab by pressing **Browse...** and choose new firmware file. Start the upgrade by pressing **Upgrade software**.

Upgrade software

Allows for upgrading of this unit's or the sub-unit's software. Please note that it is not possible to install firmware with versions lower than 1-0.6.6.

Target	New software file	Begin upgrade
Unit	<input type="button" value="Browse..."/> No file selected.	<input type="button" value="Upgrade software"/>
Sub-unit	<input type="button" value="Browse..."/> No file selected.	<input type="button" value="Upgrade PDC software"/>

Figure 19. System tab for IPC402x.

After restart of the device, which will be performed automatically, it is recommended to check the current software version and that all settings are as expected. If firmware has been upgrade from versions before 1-2.0.0, finish by saving the settings to the device (**Write to unit**).

Please note that it is not possible to downgrade firmware of the device to versions before 1-0.6.6 from firmware 1-2.2.0 or higher.

11.2 PDCIO

It is possible to upgrade firmware of a PDCIO device through IPC402x if it is physically connected to a IPC402x device and the IPC device is configured to use PDCIO.

Chose a *Bundle file* for firmware upgrade of ‘sub-unit’ on the system tab and activate the software upgrade by pressing **Upgrade PDC software**.

Please observe that updating of PDCIO firmware using IPC402x takes longer time than if it is done locally on the PDCIO device.

Always update PDCIO before IPC4020.

12 Checklist for Commissioning and Testing

1. Check the polarity and level of the auxiliary voltage before powering up the IPC402x.
2. Connect to IPC402x via the Ethernet or USB interface. Log in as **config** or **admin**.
3. Open the *Site manager* subtab.
4. Test binary inputs by applying 24 VDC at one input at a time. Verify that:
 - a. The correct LED on the unit lights up.
 - b. The corresponding LED symbol in the *Site manager* is activated.
 - c. Corresponding indication message is sent via the selected remote interface.
5. Check *Enable Manual control of outputs* box in *Site manager*. If required, disconnect the outputs from external objects. Verify that:
 - a. The correct LED on the unit lights up when activated in *Site manager*.
 - b. The correct output is activated. Measure the resistance across the output on terminal block. It should be < 1 Ohm when the relay is active.
 - c. If possible, activate the output via the remote interface.
6. If the station is in operation, the phase currents connected and with a measurable current, check that:
 - a. The correct amplitude is displayed in the *Site manager*.
 - b. The currents are symmetrically presented in *Site manager*. If the amplitudes are equal and the residual current near 0 is safe, the connection is correct.
 - c. Create a disturbance file and check that the phase sequence is the expected one.
 - d. Measurement values are displayed correctly in the remote control center.

7. To test overcurrent and earth fault detector functions:

- a. Inject current with a one or three phase instrument. Check the indications for each function of the front panel of the device, in the *Site manager*, in the *Event log* and, if possible, in the remote control end. See Figure 20.

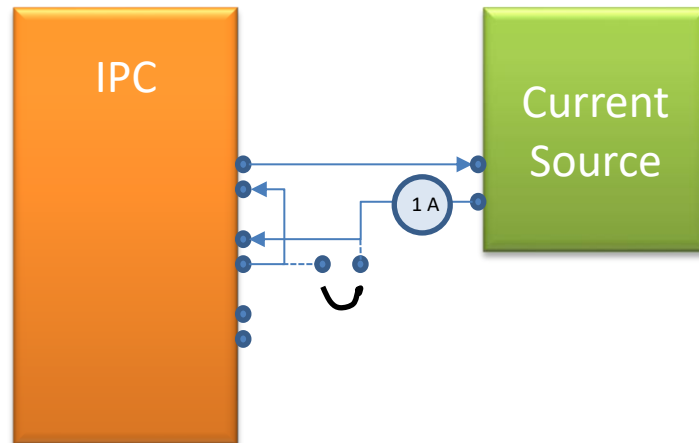

Figure 20. Current injection in two opposing phases.

- b. With a current connected in counter phase to two inputs, both overcurrents and earth faults can be verified. For testing of earth faults, typically apply 0.5 A and then short-circuit one of the phases swiftly on a terminal or directly on the plug-in contact of the device.
- c. If no current injection instrument is available and if the station is in operation with measurable currents, a simple test of the earth fault detector can be performed by short-circuiting a phase briefly on the terminal.
- d. If it is not possible to apply voltage/current on the inputs and there is no load current available, one can use simulated signals to verify the logical connection to the remote control center.

On the tab **System** it is possible to activate the function for testing signals to the remote control center by pressing the button **Activate remote signal test**.

The following text is shown:

Remote signal test mode active for another 1774 s

While this is active no physical/logical inputs will be connected to their normal inputs. These are instead controlled via the checkboxes under Config → I/O addressing → Binary inputs → Input/Detector → Remote signal test.

Clear checkboxes (Inputs) and extend remote signal test period

A new column, **Remote signal test**, is then added to the object settings for binary inputs on the tabs **Binary Inputs/Input 1-16** and **Binary Inputs/Detector m**.

Input 1-16		Detector 1				
Detector 1 inputs						
Description	Type	Settings	Delay [ms]	Address [8.16]	Remote signal test	
OC start	Single point	<input type="checkbox"/> Blocked <input type="checkbox"/> Negative <input checked="" type="checkbox"/> Timetagged	0	0-120	<input type="checkbox"/>	
OC1 trip	Single point	<input type="checkbox"/> Blocked <input type="checkbox"/> Negative <input checked="" type="checkbox"/> Timetagged	0	0-121	<input type="checkbox"/>	
OC2 trip	Single point	<input type="checkbox"/> Blocked <input type="checkbox"/> Negative <input checked="" type="checkbox"/> Timetagged	0	0-122	<input type="checkbox"/>	
EF start	Single point	<input type="checkbox"/> Blocked <input type="checkbox"/> Negative <input checked="" type="checkbox"/> Timetagged	0	0-123	<input type="checkbox"/>	

Clicking on a checkbox creates an object that is sent to the remote control center. In this way it is possible to verify that the object addresses of the IPC402x device and the remote end match. Please observe that activation of the remote signal test overrides the actual status of the binary inputs.

On the tab **System** it is possible to manually deactivate the remote signal test function by pressing the button **Deactivate remote signal test**. The device spontaneously returns to normal state 30 minutes after activation.

13 References

- [1] *IPC4020-datablad-xyyy-en.pdf*
- [2] *IPC4022-datablad-xyyy-en.pdf*
- [3] *IPC4010-12_manual_xyyy_en.pdf*
- [4] *PDC2/PDCIO_manual_xyyy_se.pdf*
- [5] *IPC4020-LIST-01_IPC402x_IEC -101-104_Settings_Template_Rev._x.xlsx*



Ensto Protrol AB, Alfagatan 3, SE-431 49 Mölndal, SWEDEN

Phone: +46 31 45 82 00. E-mail: info@protrol.se

www.protrol.se